

BrewerAccess High-Low EXAM TABLE

Installation & Operation Manual

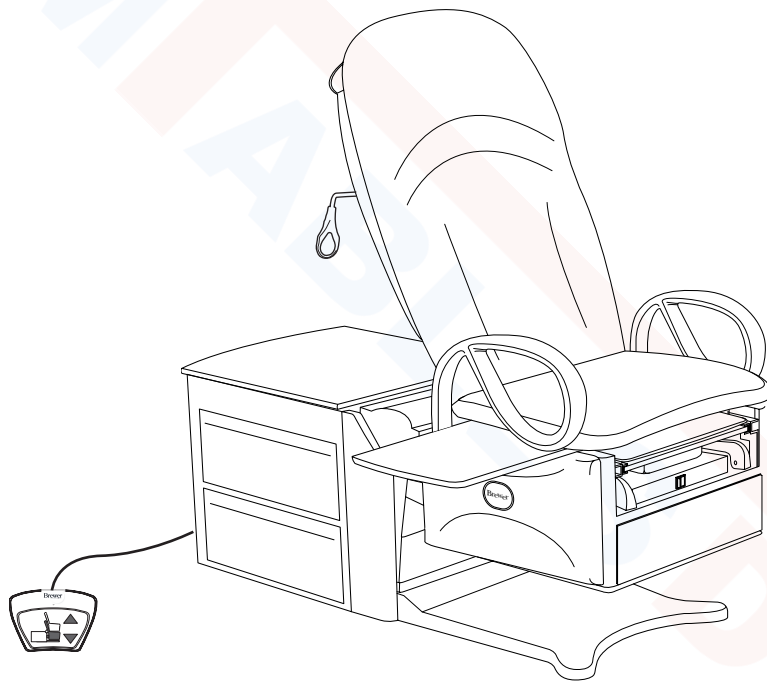

<i>Important Information</i>	2	<i>Operation</i>	14
<i>Safety Information</i>	3	<i>Table Adjustments</i>	21
<i>Component Identification</i>	3	<i>Maintenance</i>	24
<i>Specifications</i>	4	<i>Service</i>	25
<i>Installation</i>	5	<i>Warranty</i>	26
		<i>Accessories</i>	26

The Brewer Company, LLC
N88 W13901 Main Street, Suite 100
Menomonee Falls, WI 53051
P 1.888.Brewer.1
F 262.251.2332
www.brewercompany.com

IMPORTANT INFORMATION

General

Read and understand all operating instructions, safety information, and maintenance requirements contained in this manual prior to operating the table. Become familiar with all of the table functions before using it with a patient.

The Brewer Access High-Low Exam Table Model 6000 Series is designed to provide positioning and support of patients during general examinations conducted by qualified medical professionals.

The Brewer Access High-Low Exam Table is primarily used in examination rooms for general examinations and minor procedures. The wide variety of positions provided by one or two powered motions, and slide-out leg support create a safe and convenient patient positioning table for use in the doctor's office.

The table is easily adjusted to a wide variety of positions using the convenient foot control provided with the table. The table height can be adjusted from 18" to 37". The table seating surface on models 6001, 6501, and 6801 can be moved from the normal horizontal position to an angle of 5°. The backrest can be adjusted from a flat lying down position, to an 80° angle for seating.

In addition to the electronically controlled positions noted above, several manual adjustments are available:

- The SafeGlide™ leg support can be extended up to 18" for the patient prone position.
- Stirrups may be manually extended through infinite positions and four lateral positions.
- A removable treatment pan is built-in underneath the leg extension for use during examinations.
- Grab bars attached to each side of the table may be rotated out of position or removed for improved access to the patient.
- A pass through work surface, stored under the seat, may be pulled out from either side of the table.
- Storage drawers at the front and side of the table may be used for supplies. The pass through side drawers may be pulled out from either side of the table.
- A storage cover at the rear of the table can be lifted to store paper rolls.

Service

If you require assistance with the installation or operation of your Brewer table, call the Brewer Customer Service Department at **(1-888-Brewer1)**. Our trained staff will attempt to assist you in correcting the problem directly over the phone. If service is required, a factory authorized technician will be sent to your location.

Please fill in the following information for use when calling the Brewer Company or your distributor with questions regarding your unit. See the figure below for model and serial number location.

Date of Purchase _____

Serial Number _____

Model Number _____

Authorized Dealer Name _____

Dealer Phone Number _____

Dealer Address _____

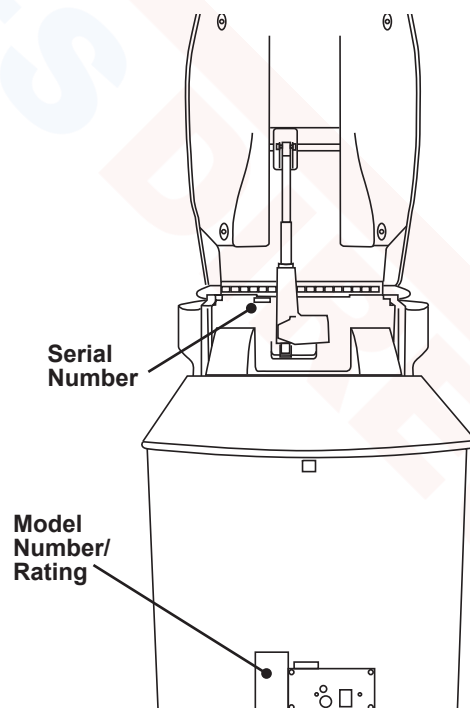

Serial Number and Model Number/Rating Label Location

SAFETY INFORMATION

Safety Information

The primary concern of The Brewer Company is that the equipment is operated and maintained with the safety of the patient and healthcare staff in mind. To ensure safe and reliable operation:

- Read and understand all instructions in this manual before attempting to install or operate the unit.
- Ensure that appropriate personnel are informed on the manual contents. This is the responsibility of the purchaser.
- Ensure that this manual is located near the table, or if possible permanently affixed to the table.



This is the safety alert symbol. It is used to alert you to potential physical injury hazards. Obey all safety messages that follow this symbol to avoid possible injury or death.



DANGER Indicates a hazardous situation that, if not avoided, will result in death or serious injury.



WARNING indicates a hazardous situation which, if not avoided, could result in death or serious injury.



CAUTION indicates a hazardous situation which, if not avoided, could result in minor or moderate injury.

COMPONENT IDENTIFICATION

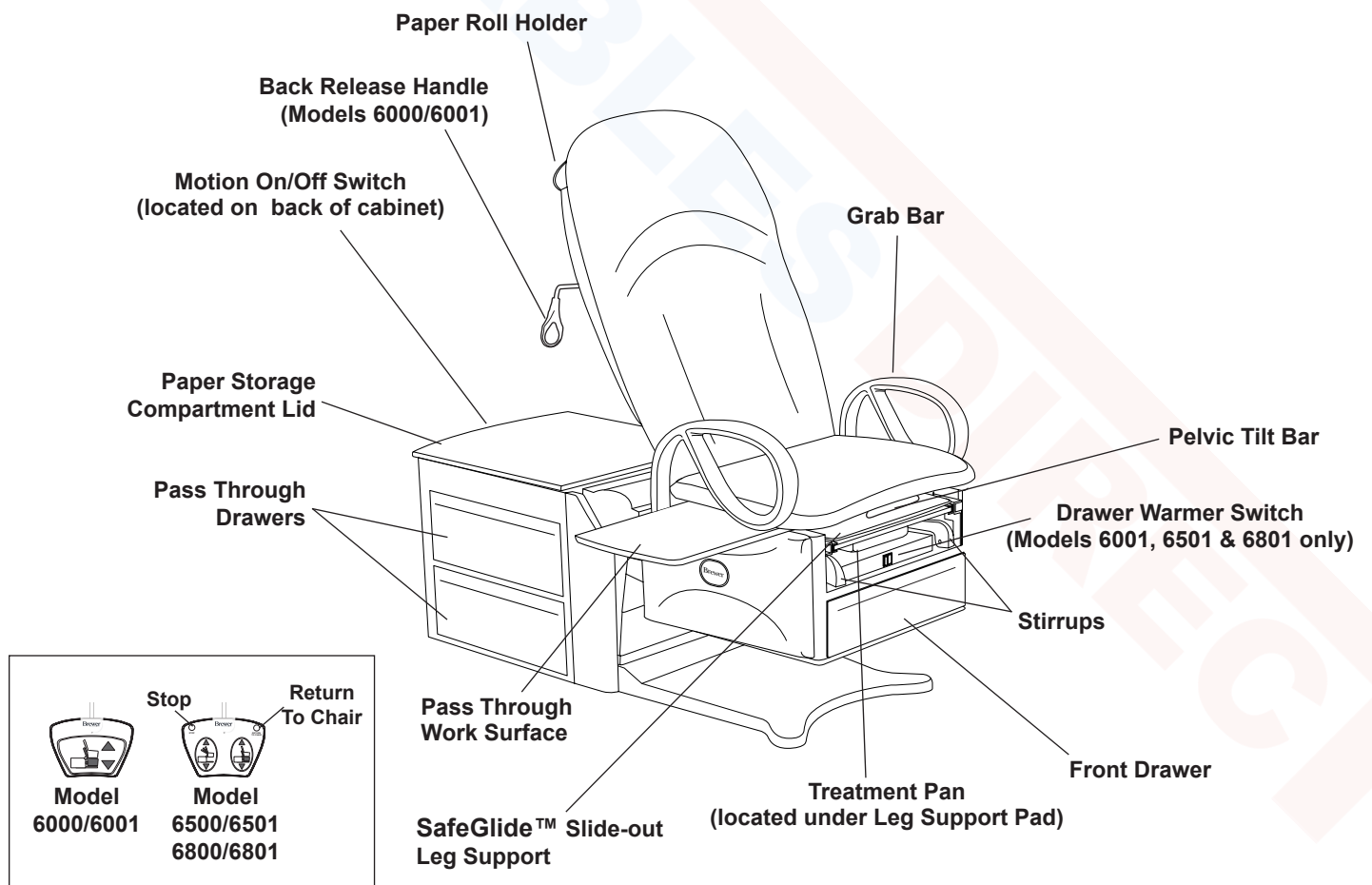

Figure 1. Component Overview

SPECIFICATIONS

Weight of Table

- Models 6000, 6001, 6500 & 6501..... 395 lbs
- Model 6800 423 lbs
- Model 6801 432 lbs

Load Rating (maximum)

- Seat/Back 6800/6801 700 lbs.
- Seat/Back 6000/6001/6500/6501 450 lbs.
- Leg Support 50 lbs.
- Pass Through Work Surface 15 lbs.
- Grab Bars 100 lbs.

Back Section Range 0° (horizontal) to 75-85°

Table Top Height Range 18 ± 0.5 in. to 37 ± 1.0 in.

Pelvic Tilt Range

(Models 6001/6501/6801 Only) 0° (horizontal) to 5° (up)

Upholstery Dimensions

- Upholstered Top 28.0 in. wide x 60 in. long
- Upholstered Leg Support 18 in. long x 18 in. wide
- Overall Length 60 in. long
- With Leg Support Extended 78 in. long

Electrical Rating

- 6000/6500/6800 115 VAC nominal, 60 HZ, 6.0 amps max.
- 6001 115 VAC nominal, 60 HZ, 6.0 amps max.
- 6001/6501/6801
W/Outlet 115 VAC nominal, 60 HZ, 6.0 amps max.
- Fuse rating:
- Control Box Fuse Rating 250V/2.5A
- Option/Warmer Fuse Rating 250V/1.0A
- Option/Warmer & Outlet Fuse Rating 250V/3.0A
- Outlet Max Load 2.0A

Duty Cycle (10%)

..... 2 minutes on / 18 minutes off (motor run time)

Power Cord

- Length Extends 70 in. minimum from table.
- Type (6000, 6500, 6800) Attached
- Type (6001, 6501, 6801) Detachable
- Conductors 18 AWG / 3 Conductor
- Grade Hospital Grade Plug

Type of protection against electrical shock

- Model 6000, 6500, and 6800 .. Class 2 Double Insulated
- Models 6001, 6501, and 6801 Class 1 Grounded
- Patient applied parts (all models) Type B

Type of protection against ingress of water Ordinary Paper Roll Sizes

- Regular 18 in. x 3.5 in.
- Long 21 in. x 3.5 in.

Certifications*... ..UL60601-1; CAN-CSA C22.2 No. 601.1

Operating Conditions

- Temperature Range 65° to 85°F
- Humidity Range 10% to 90%

Transportation and Storage

- Temperature Range -20°F to 150°F
- Humidity Range 10% to 90%

*Classified in the United States and Canada per the standards listed above.



WARNING	
	<p>Explosion/Fire Hazard</p> <p>Do not use this table in an explosive or oxygen rich atmosphere. Failure to do so may result in serious personal injury or death.</p>

WARNING	
	<p>Shock Hazard</p> <p>When performing cauterization or similar treatment, the patient must be insulated from the metal portions of the table by non-conductive material. Failure to do so may result in electrical shock.</p>

NOTICE
<p>Certifications</p> <p>This product has been evaluated with respect to electrical shock, fire, and mechanical hazards only in accordance with UL60601-1; CAN/CSA C22.2 No. 601.1</p>

NOTICE
<p>Electromagnetic Interference (EMI)</p> <p>This product is designed and built to minimize electromagnetic interference with other devices; however, if interference is noticed between another device and this product, remove the interfering device from the room or plug this product into an isolated circuit.</p>

INSTALLATION

NOTICE

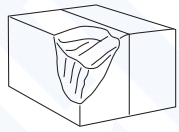

Inspect Carton and Contents

Inspect all boxes and contents for damage. Report any damage to the carrier immediately.

NOTICE



No Sharp Tools

To avoid damaging the table's upholstery or painted surfaces, DO NOT use a knife or other sharp object to open the packaging.

Overview

Perform the following sequence in order when setting up the table:

- Uncrating the table
- Leveling the table
- Installing Power Cord
- Installing Foot Control
- Installing Grab Bars

Tools Required

Drill Driver, 7/16" socket bit, or 7/16" wrench, #2 Phillips bit, side cutter, furniture dolly.

NOTICE

Optimum Table Performance

For optimum table performance, allow the table to reach room temperature before operating.

Uncrating

1. Remove stretch wrap surrounding table.
2. Remove the 6 steel shipping brackets securing the table to the pallet (Figure 2). The brackets hook onto the table levelers to hold the table securely to the pallet. Remove the 2 bolts from each bracket using a 7/16" socket or wrench. Take care not to scratch the unit when using the driver or turning the wrench. Remove brackets from levelers once bolts are removed.
3. Remove the 2 screws attaching the spacers on either side of the wooden U-shaped brace located under the front corners of the cabinet (Figure 3). Remove the 2 screws attaching the U-shaped brace to the pallet (Figure 3).

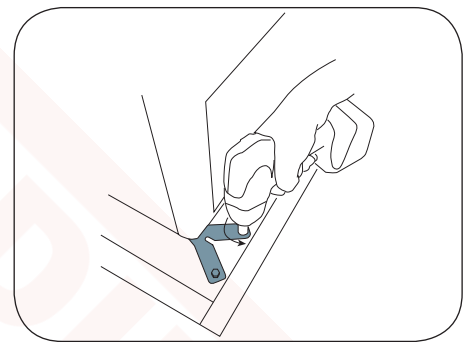

Figure 2. Remove Shipping Brackets

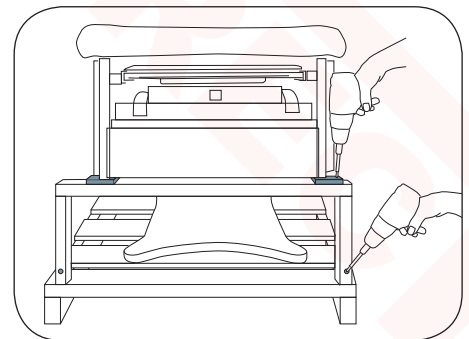

Figure 3. Remove Spacer and U-Brace Screws

INSTALLATION (continued)

- Cut the shipping strap, and discard strap and foam tube (Figure 4)..
- Make sure all shipping materials (except for wooden brace and spacers) and packing foam are removed from the table, pallet and surrounding area.

Note: In order to remove the table from the pallet, you must first power it up and elevate the seat from it's shipping position.

NOTICE



Avoid Self Activation Damage

Plugging table into receptacle prior to the removal of all packaging materials, may cause damage if self activation occurs.

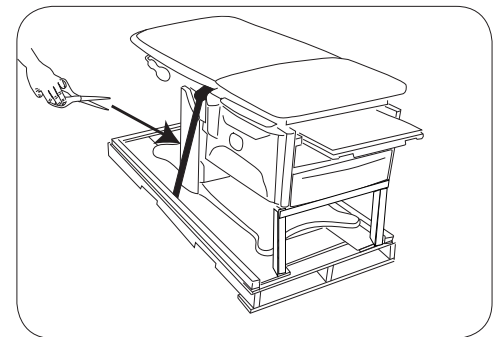

Figure 4. Cut Shipping Strap

- Remove the foot control from the rear drawer.
- Insert the foot control cord into the receptacle at the bottom of the rear panel (Figure 5). Make sure the pins are properly orientated and the plug is fully seated. Turn the locking ring clockwise to secure the plug to the table.
- For models 6001, 6501, and 6801, remove the power cord from the rear drawer. Models 6000, 6500, and 6800 have the power cord already installed.

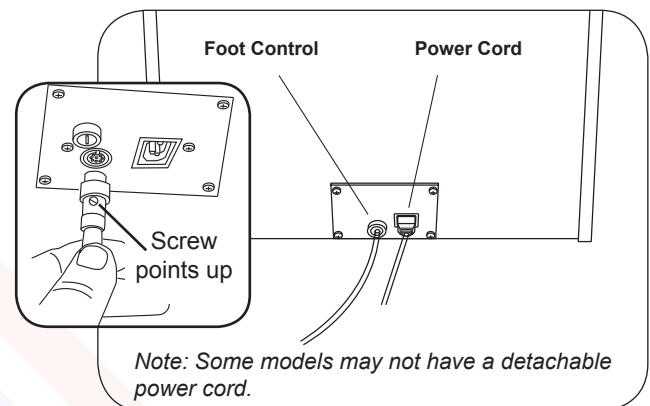

Figure 5. Power Cord and Foot Control Plug-ins

NOTICE

Confirm Voltage and Plug Type

See Specifications Page for electrical rating of this unit. The three-pronged grounding plug on the table power cord must be plugged into a matching three-pronged, grounded, non-isolated, correctly polarized 115 VAC receptacle.

- Plug the female end of the power cord into the receptacle at the bottom of the rear panel (Figure 5). Plug the male end of the power cord into a 115 Volt grounded receptacle. Make sure the black Motion On/Off Switch at the back of the table is on (Figure 6).

WARNING

Area Not Clear Hazard

Before initiating movement keep personnel and equipment clear of table to avoid personal injury or damage to the equipment.

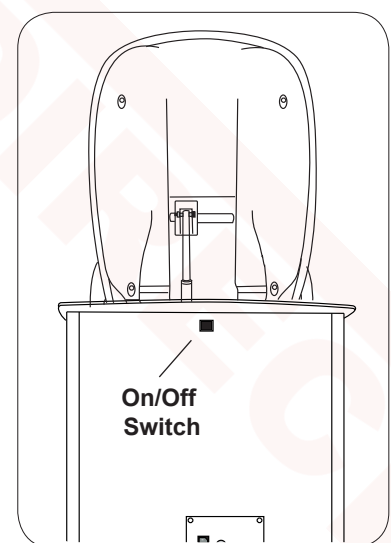

Figure 6. Motion On/Off Switch

INSTALLATION (continued)

10. Press “Lift Up” on the foot control to raise the seat approximately 1” (Figure 7).

11. Remove the wooden U-brace and shipping spacers at the front of the table.

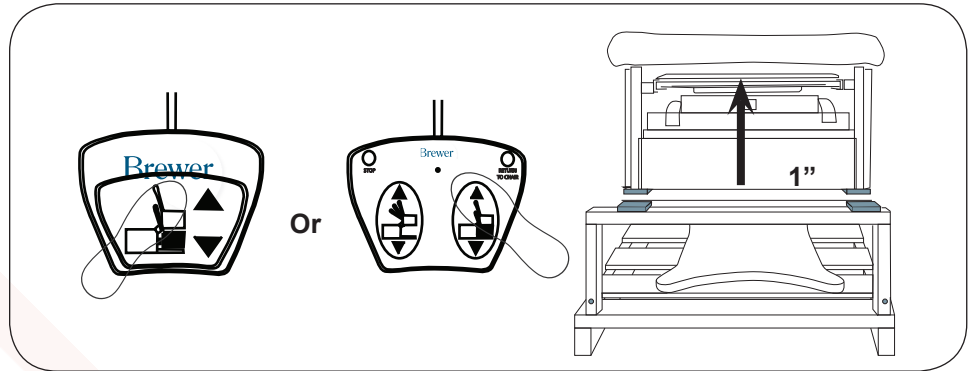

Figure 7. Raise Seat off of Brace

12. Unplug foot control and power cord and place into rear storage drawer (Figure 9).

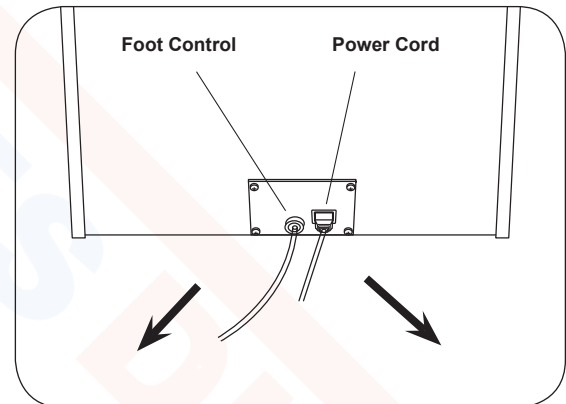

Figure 9. Power Cord and Foot Control Plugs

INSTALLATION (continued)

NOTICE

Avoid Pelvic Tilt and Upholstery Damage

Do not lift or move table by pulling up on the seat upholstery (Figure 10). Lifting by the seat will damage the pelvic tilt mechanism (if equipped) and may damage the upholstery.



Figure 10. DO NOT Lift by Upholstery

NOTICE

Avoid Backrest Actuator and Upholstery Damage

Never push forward on the backrest to move table. Pushing on the backrest will cause backrest actuator damage and may cause upholstery damage (Figure 11).



Figure 11. DO NOT Push on Backrest

NOTICE

Avoid Stirrup Damage

Do not lift or move table by using the stirrups as a hand hold. Lifting or moving table by stirrups can damage the internal indexer housing (Figure 12).

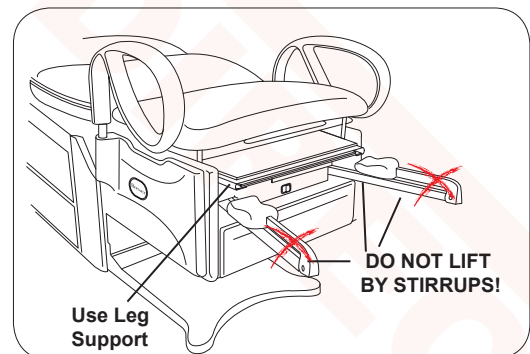

Figure 12. DO NOT lift by Stirrups

INSTALLATION (continued)

13. Prepare the front of the table for lifting by pulling out leg support approximately 6" (Figure 13). DO NOT fully extend leg support as damage to the slide mechanism may occur.

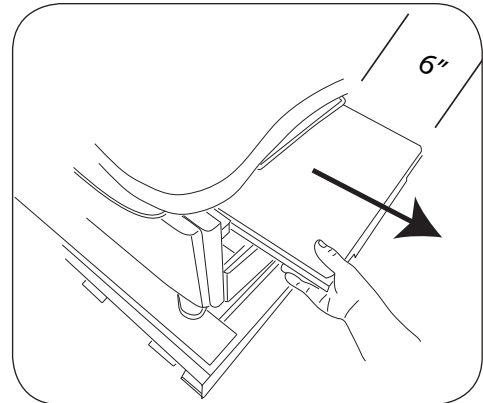

Figure 13. Leg Support Pulled Out 6"

14. Prepare the rear of table for lifting by pulling top rear pass-through drawer to one side (Figure 14).

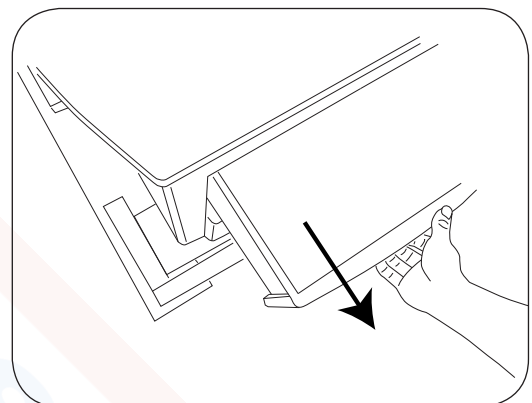

Figure 14. Pull Top Rear Pass-through Drawer Open

15. Position furniture dolly close to pallet for transfer of table (Figure 15).

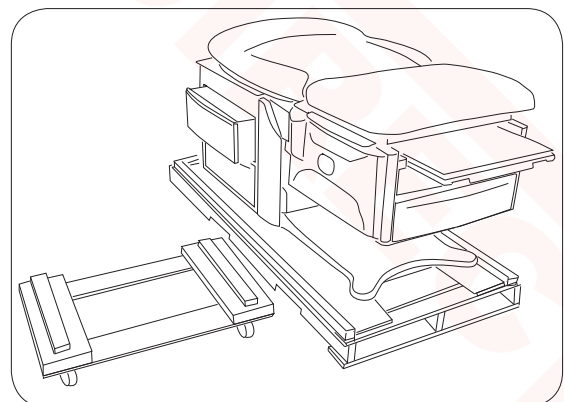

Figure 15. Furniture dolly ready for table

INSTALLATION (continued)

16. Position personnel at the front and rear of the table. Front lifting points are the left and right sides of the leg support (Figure 16).

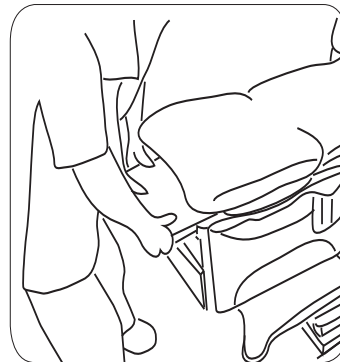

Figure 16. Front Lift Points

17. Rear lifting points are provided by the top rear pass through drawer openings at the left and right sides (Figures 17, 18, and 19).

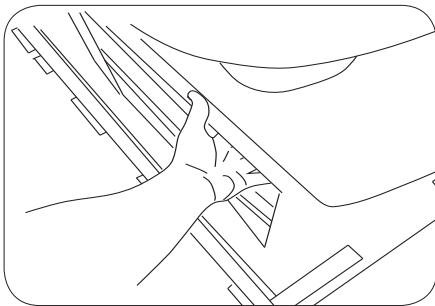

Figure 17. Left rear hand hold

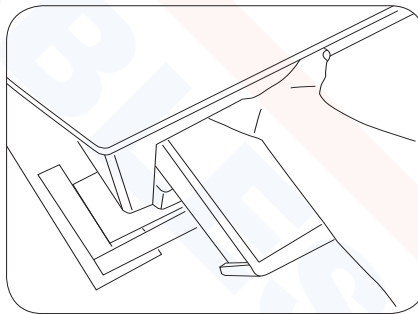

Figure 18. Right rear hand hold

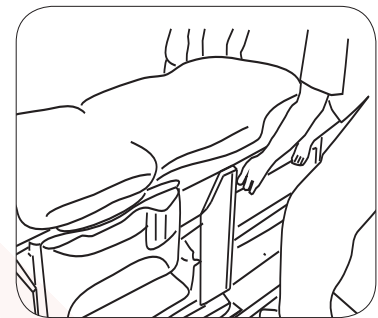

Figure 19. Rear Lift Points

NOTICE

Table weight up to approximately 432 lbs.

18. For safety, move table onto furniture dolly in two steps. Lift table straight up, move half-way off of pallet and lower straight down (Figure 20).
19. Obtain new footholds and hand holds. Lift table, move to furniture dolly and lower.

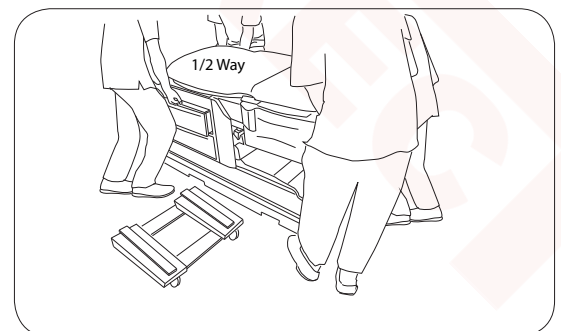

Figure 20. Lift, move half-way and lower

INSTALLATION (continued)

20. Move table to its final location. Lift off of furniture dolly and set down into position. Do not push or pull sideways on Leg Support when positioning table.(Figure 21)



Figure 21. Do not move by fully extended leg support

Leveling the Table

A leveling screw pad (Figure 22) is located in six places under the table's base and rear cabinet. Adjust the six leveling pads to achieve a solid, level installation.

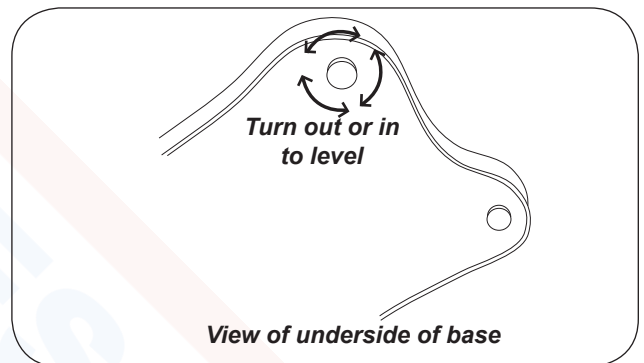

Figure 22 Leveling Screw Pad (located under table)

NOTICE

Prevent Leveler Damage

Levelers must remain in the table and be fully engaged a minimum of (3) turns. If levelers are not fully engaged in the base, damage to the threading in the base and/or leveler can occur.

NOTICE

Prevent Floor Damage and Unwanted Table Movement

Make sure the rubber caps are present on all (6) levelers. Missing caps can allow the table to slide, and the exposed metal portion of the leveler can damage flooring.

INSTALLATION (continued)

**Installing the Power Cord
(Models 6001, 6501 and 6801)**

1. Remove the power cord from the rear drawer.
2. Insert the female plug end of the power cord into the receptacle on the table (Figure 23). Make sure the plug is fully seated.

Note: The power cord is installed at the factory on models 6000, 6500 and 6800.

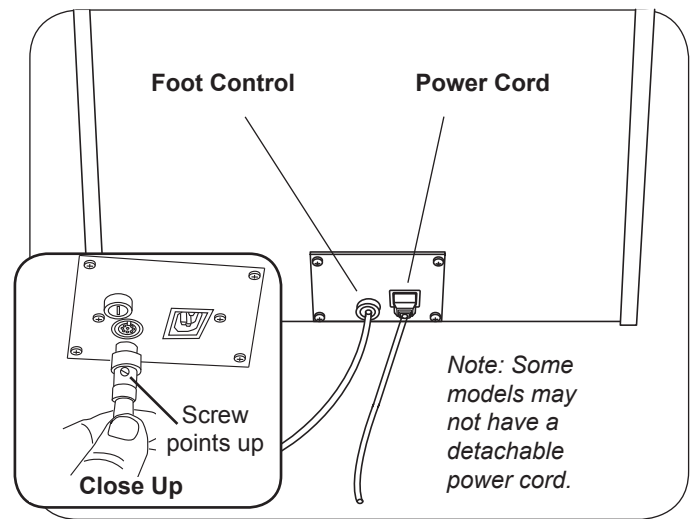

Figure 23 Power Cord and Foot Control.

NOTICE

Confirm Voltage and Plug Type

See Specifications Page for electrical rating of this unit. The three-pronged grounding plug on the table power cord must be plugged into a matching three-pronged, grounded, non-isolated, correctly polarized 115 VAC receptacle.

Installing the Foot Control

1. Insert the male plug of the foot control cord into the receptacle on the table (Figure 23). Make sure the pins are properly orientated and the plug is fully seated.
2. Turn the locking ring clockwise to secure the plug to the table.

NOTICE

Avoid Foot Control Damage

The foot control is moisture resistant and runs on low voltage, eliminating shock hazards. However, to avoid temporary or permanent damage to the foot control, do not immerse in water or liquids.

INSTALLATION (continued)**Installing Grab Bars**

1. Remove grab bars from drawer.
2. Grab bars are interchangeable and may be installed on either side.
3. Align pin on grab bar shaft with mating slot on side of table. See Figure 24.
4. Push grab bar all the way down and rotate to front of table.
5. Push grab bar down until it engages to prevent left or right movement.

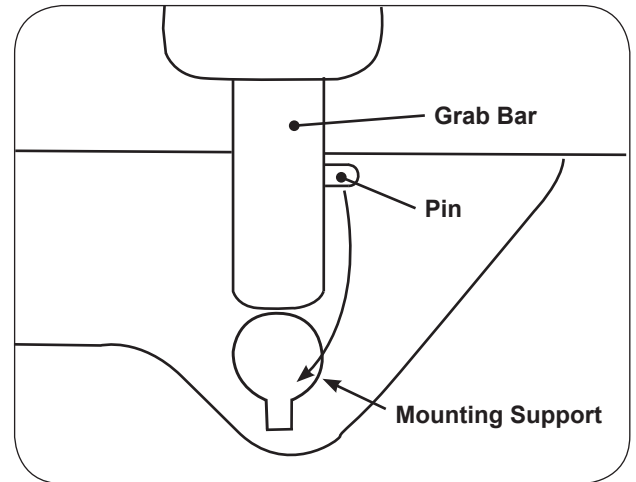

Figure 24. Grab Bar

WARNING**Shock Hazard**

After installing or moving table, make sure there are no damaged or exposed wires that could result in electrical shock.

OPERATION

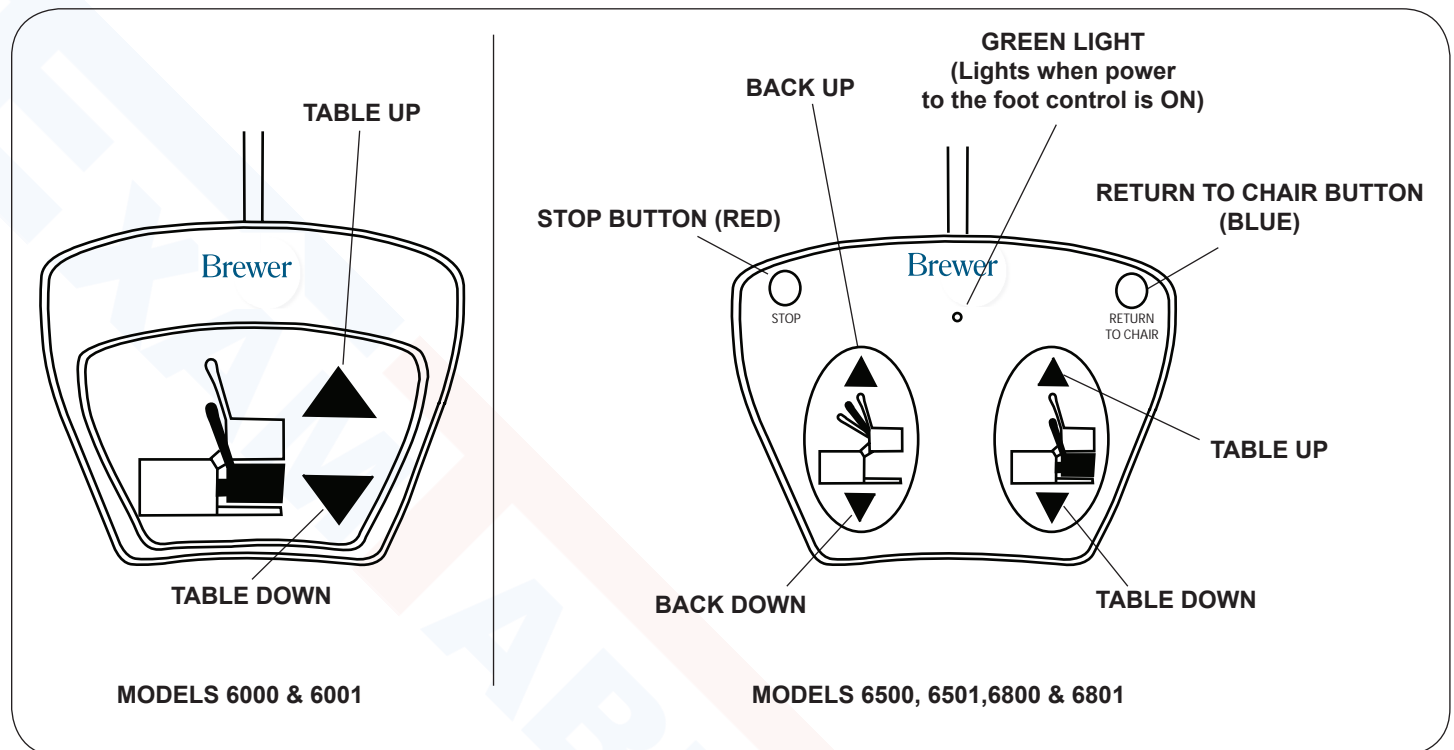

Figure 25. Foot Controls

Models 6000 & 6001

Models 6000 and 6001 are equipped with a single pedal foot control that raises and lowers the seat.

Models 6500, 6501, 6800 & 6801

Models 6500, 6501, 6800 and 6801 are equipped with a dual pedal foot control that controls the raising/lowering of the seat, and raising/lowering of the seat back. In addition, the foot control features the following:

Return to Chair: When pressed, the table automatically returns to the low chair position. The seat back will rise to the full up position and the table will lower to the full down position and stop. To stop the automatic movement, press the Red Stop Button, or depress any pedal on the foot control.

Stop: When pressed, stops the return to chair function.

Green Light: (2 Pedal Foot Controls Only) Indicates that there is power to the foot control (Motion On/Off switch at back of table is ON).

NOTICE

Unintended Operation

To avoid unintended operation, keep foreign objects away from foot control. Be sure foot control is not positioned below the front of the table.

NOTICE

Unattended Return to Chair Operation

Remain with and observe patient during Return to Chair operation. Return to Chair feature may need to be momentarily interrupted for patient to readjust him or herself, or for obstacles to be removed before resuming motion. Press the Return to Chair button to resume motion only when patient has situated him or herself, or obstacles have been removed.

OPERATION (continued)

Seat and Backrest Safety Switches

All Models

All models are equipped with safety switches. They are located inside the backrest cover, on the seat back, and on the bottom of the chair assembly. Each safety switch automatically stops the lowering function if an obstruction is encountered (Figure 26).

Seat Switch

All models are equipped with switches on the seat bottom (Figure 26) which automatically stops the lowering function of the seat if the seat bottom plate comes into contact with an object as the seat is lowering. To continue lowering the seat, press the "TABLE UP" pedal (Figure 25), clear the obstruction, and continue lowering the seat.

Backrest Switch

Powered Backrest

Models 6500, 6501, 6800 and 6801 are equipped with safety switches inside the backrest cover which automatically stops the lowering function of the seat and back if an obstruction is encountered. To continue lowering the backrest, press either the "TABLE UP" or "BACK UP" pedal (Figure 25), clear the obstruction, and continue lowering the backrest.

Manual Backrest

Models 6000 and 6001 with manual backrest are equipped with safety switches inside the cover backrest which automatically stops the lowering function of the seat if an obstruction is encountered. To continue lowering the seat, press the backrest release handle to raise the backrest (Figure 1), clear the obstruction, and continue lowering the seat.

Motion On/Off Switch

All Models

The Motion On/Off switch (located on the back of the rear cabinet, Figure 27) can be set to the OFF position to disable all movement of the table. Power to the drawer warmer (if so equipped) and other portions of the table will remain on.

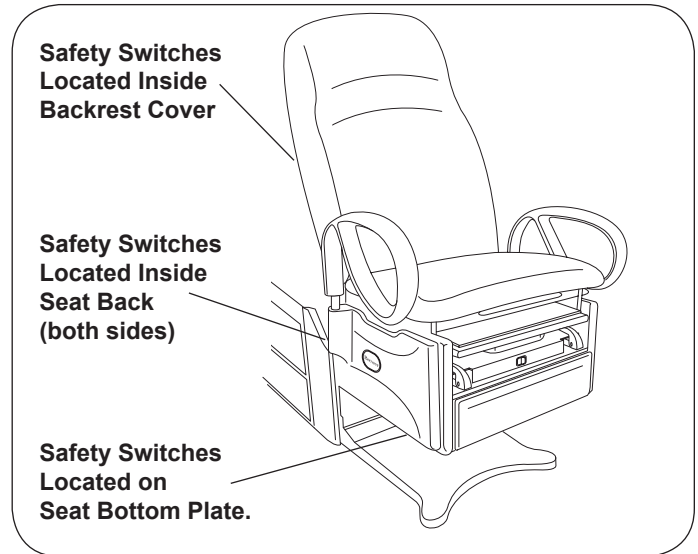

Figure 26. Seat and Backrest Safety Switches

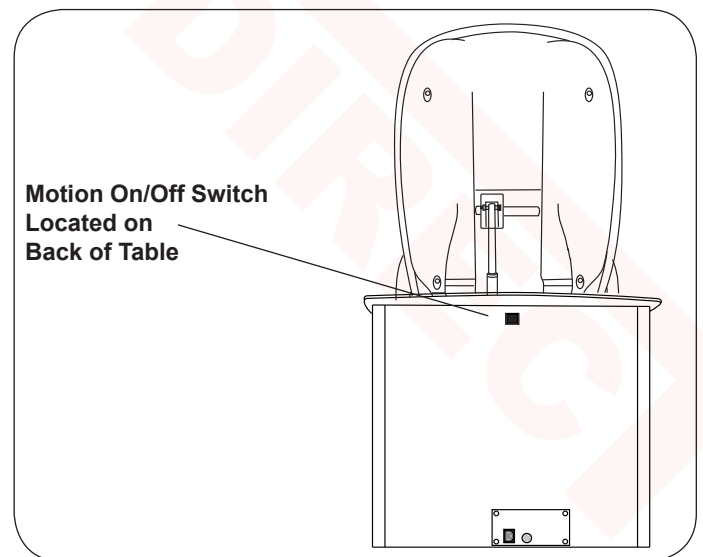

Figure 27. Motion On/Off Switch

OPERATION (continued)

SafeGlide™ Leg Support

The leg support is located under the seat cushion. (Figure 28). It can be extended 18" for the patient prone position. Pull leg support out to the fully extended position. To return the leg support to its stored position simply push the leg extension in.

WARNING	
	<p style="text-align: center;">Fall Hazard</p> <p>The leg support is rated for 50 lbs and is not intended for use as a seat. Sitting on leg support could cause it to retract, bend, or cause the table to tip forward, creating a fall hazard leading to serious injury.</p>

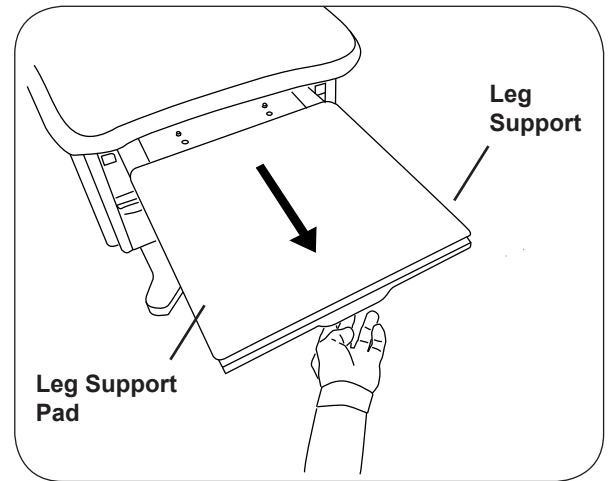

Figure 28. Leg Support Pull Out

Leg Support Pad

The leg support pad can be slid beneath the seat with the leg support extended for easy access to the treatment pan (Figure 29). Pushing the leg support back in will allow the glides on the pad to drop into slots. The pad will once again come out with the leg support the next time it is pulled out.

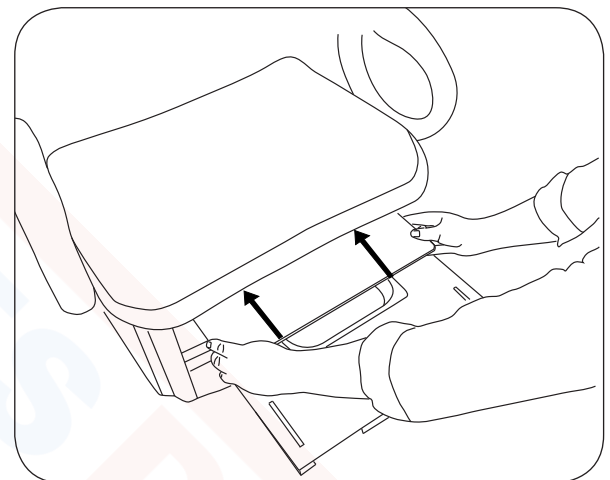

Figure 29. Slide Foot Pad Back

Treatment Pan

A removable treatment pan is built-in underneath the leg support pad for use during examination. Pull the leg support fully out and remove the leg support pad or slide it back under the seat to access the pan (Figure 30). Remove the treatment pan for cleaning.

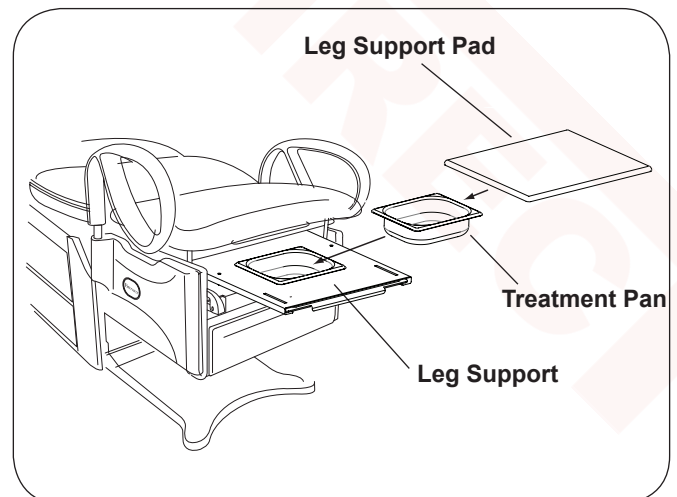

Figure 30. Treatment Pan

OPERATION (continued)

Front Drawer

A storage drawer for supplies is located at the front of the table. Models 6001, 6501 and 6801 are equipped with a drawer warmer that is turned on by a switch located above the drawer (Figure 31).

NOTE: The warmer element is located above the drawer and applies radiant heat to the drawer contents. Items closer to the element will be warmer than items at the bottom of the drawer. Avoid stacking instruments or allowing instruments to tip and contact the element.

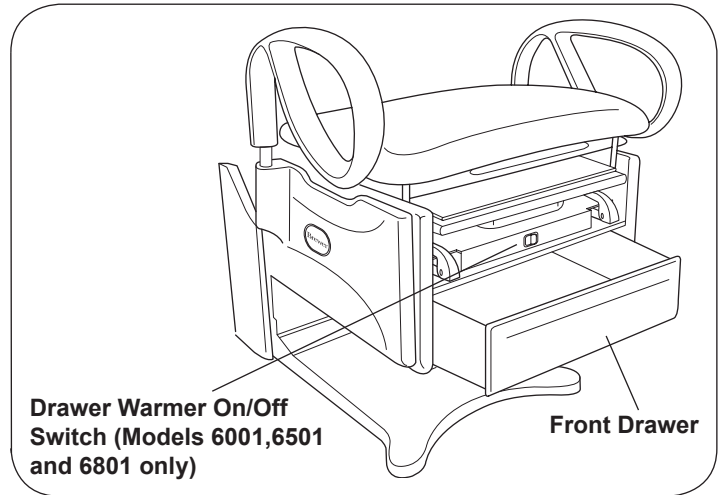

Drawer Warmer On/Off Switch (Models 6001,6501 and 6801 only)

Front Drawer

Figure 31. Drawer Warmer Switch and Front Drawer

Paper Roll Holder

To change a paper roll, place the paper into the holder located on the rear of the seat back (Figure 32). Pull the end of the roll over the top of the seat back and place in the desired position.

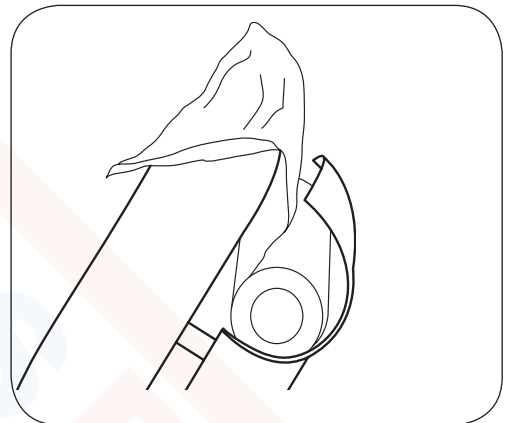
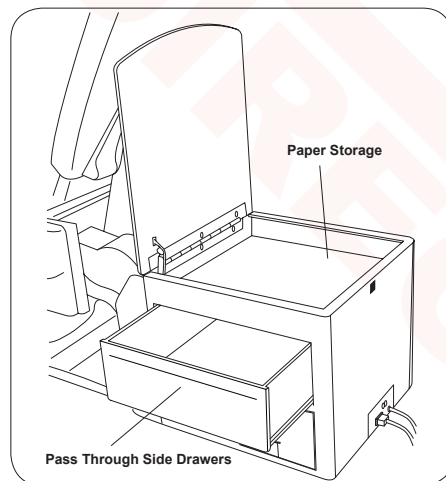

Figure 32. Paper Roll Installation

Paper Storage

With the seat back in the upright position, lift the lid on the rear of the table to access the paper storage compartment (Figure 33).



Paper Storage

Pass Through Side Drawers

Figure 33. Paper Storage

OPERATION (continued)

Pass Through Side Drawers

Two storage drawers are built into the table cabinet for supplies (Figure 34). The drawers may be pulled out from either side of the table.

Installing Drawer Stops

The Brewer Access High-Low Exam Tables are supplied with two drawer stops for the side pass through drawers. If you wish to restrict the drawers to opening only on one side, simply install one drawer stop per drawer on the opposite side the drawer is to be opened (See Figure 34.)

To install drawer stops:

1. Pull drawers out on the side of desired use.
2. Screw in one drawer stop, one for each drawer on opposite side of cabinet. (Figure 34).

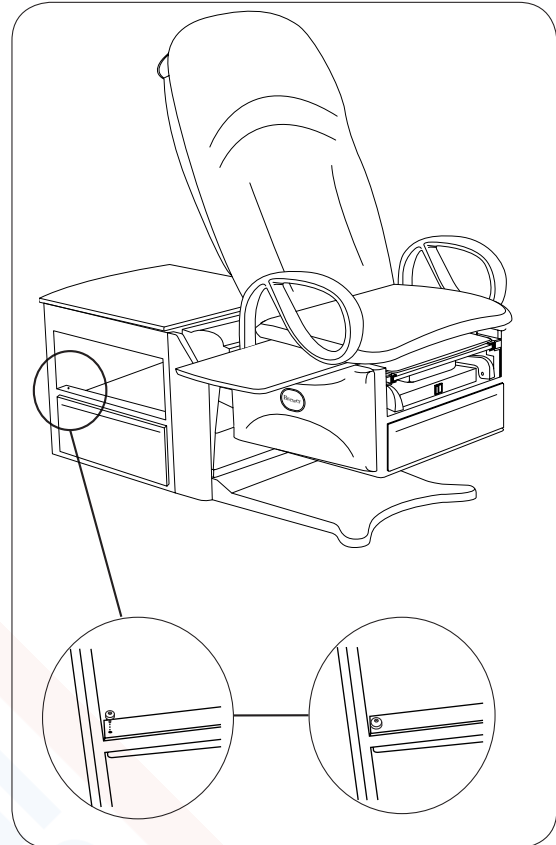

Figure 34. Drawer Stops

Pass Through Work Surface

A pass through work surface, stored under the seat (Figure 35), may be pulled out from either side of the table. Grasp the edge of the work surface and pull until it is fully extended. Push it fully in to stow after use.

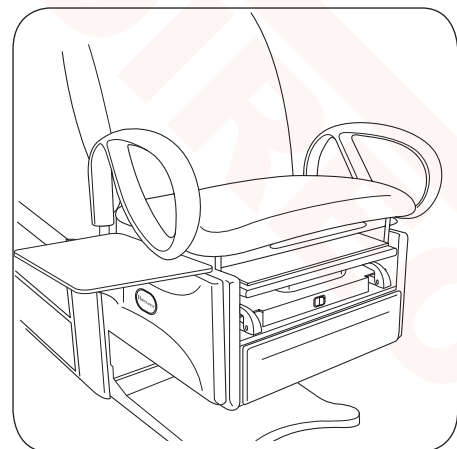

Figure 35. Pass Through Work Surface

WARNING



Fall Hazard

The work surface is rated for 15 lbs. and is not intended for use as a seat. Sitting on work surface could cause it to bend or break or cause the table to tip creating a fall hazard leading to injury.

OPERATION (continued)

Removing the Work Surface for Cleaning

1. Push work surface in, to reveal a white plastic screw.
2. Remove the white plastic screw. (Figure 36.)
3. Pull the work surface toward you and remove it.
4. Reinsert screw after replacing work surface.



Figure 36. Location of White Plastic Stop Screw

Grab Bars

In the forward (normal use) position the grab bars lock into place preventing left or right rotation.

The grab bars can be rotated to the side or toward the back of the table for improved access and stability of the patient. Pull up on the grab bar and rotate to the desired position. The grab bar locks in the front, side and rear positions (Figure 37).

The grab bar can be removed from the table by pulling up on the grab bar, rotating it to the 90° position, and then lifting it out of it's holder.

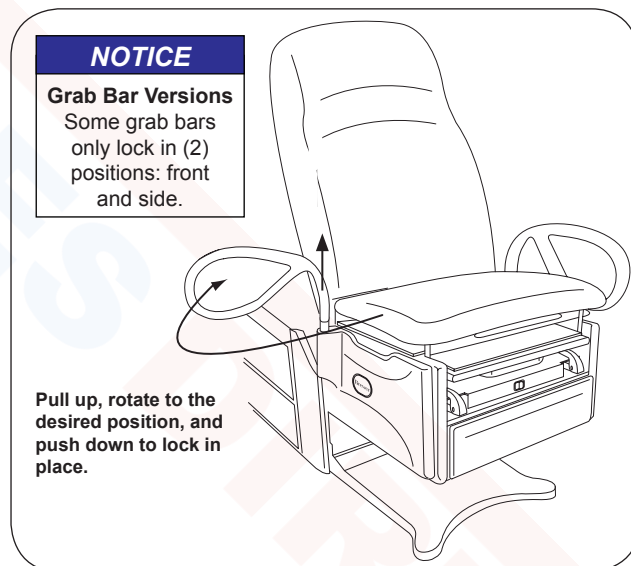

Figure 37. Grab Bar Adjustment

OPERATION (continued)

Adjustable Stirrups

Operating the Stirrups (Figure 38)

1. To operate the stirrups, grasp end of stirrup and pull straight out of the table. Lift up slightly while sliding the stirrup out.

NOTE: Applying downward pressure when pulling stirrup from table may make it difficult to move. Resistance is normal and is part of the stirrup friction locking mechanism.

2. Unfold stirrup upward to the fully open position.
3. Adjust the stirrup to the desired length by sliding it in or out.

Stirrup Lateral Adjustment

1. Lift end of stirrup slightly and then rotate outward to desired position.
2. When the desired position is achieved, lower the stirrup to engage the lateral locking mechanism (Figures 38 and 39).
3. Check that lateral locking mechanism is engaged by attempting to move stirrup assembly side-to-side without lifting on the stirrup end.

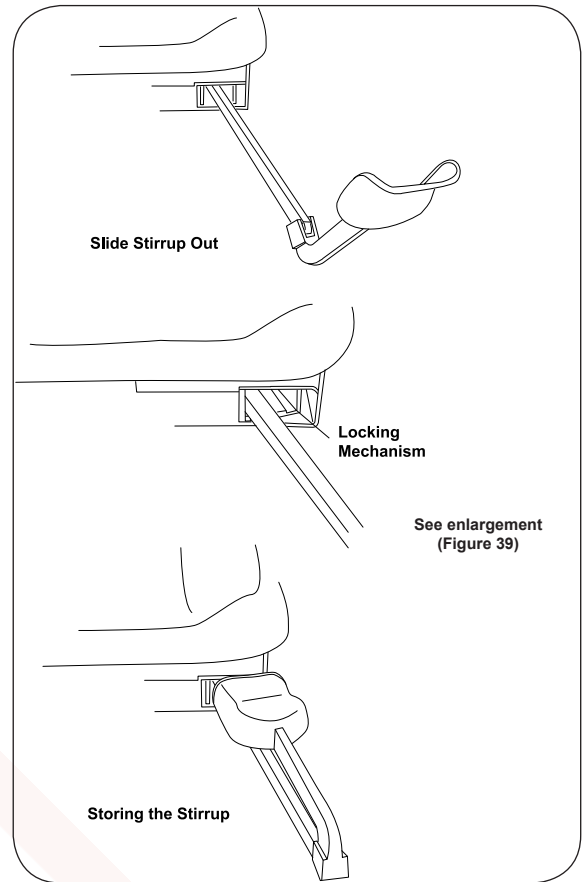

Figure 38. Stirrups

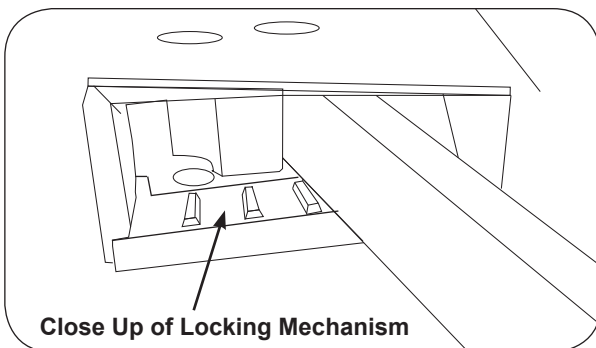

Figure 39. Stirrup Locking Mechanism

Storing the Stirrups

1. To store the stirrups in the table, grasp end of stirrup and pull straight out to its full extension.
2. Fold stirrup down against bar, then rotate it to the inner most lateral position and slide it back into the stowed position.

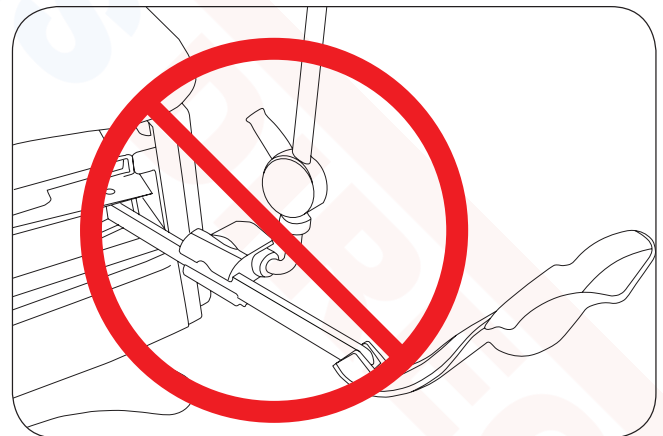

Figure 40. Affix No Attachments!

NOTICE

Use Stirrup Only as Designed

Do not use any part of the stirrup for attachment of any device (Figure 40). Warranty will be voided. If knee crutches are required for use, order mounting adapters and clamps shown in the Accessories Section.

TABLE ADJUSTMENTS

WARNING

Area Not Clear Hazard

Before initiating movement keep personnel and equipment clear of table to avoid personal injury or damage to the equipment.

Table Height

The table can be adjusted to any height between 18" to 37" (Figure 41).

1. To raise the table, depress and hold the Table Up pedal until the desired height is achieved, then release the pedal.
2. To lower the table, raise the backrest to the upright position, then depress and hold the Table Down pedal until the desired height is achieved, then release the pedal.

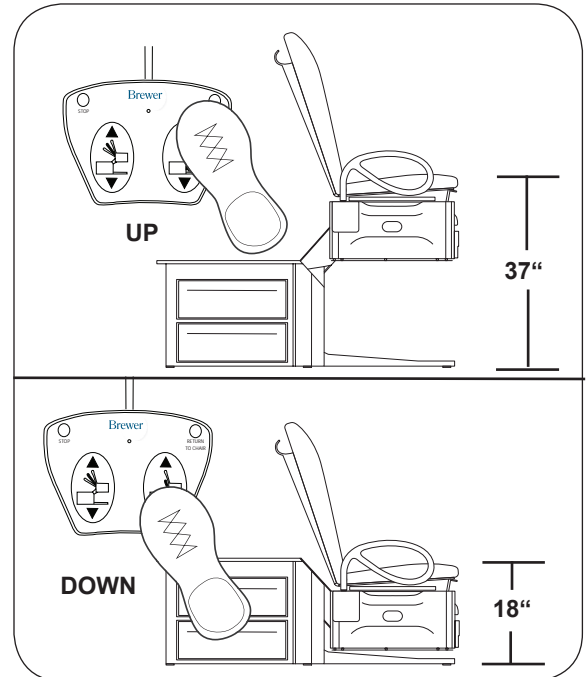

Figure 41. Table Height Positioning

3. Press the blue button to engage the Return to Chair feature. (Figure 42)

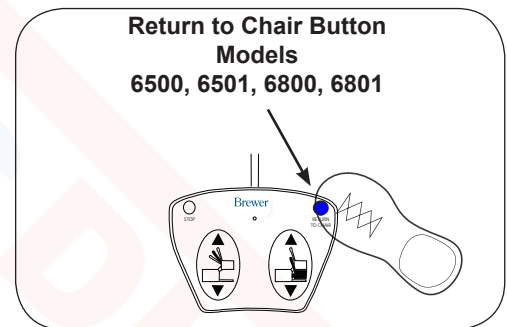

Figure 42. Lowering with Return to Chair

NOTICE

Actuator Travel Limit Protection

Each control function will automatically stop moving when either the UP or DOWN travel limit is reached. If the foot pedal is pressed with travel at its limit, the actuator will not operate. Sensors prevent the actuator motor from operating when travel limit has been reached, preventing wear of the actuator.

NOTICE

Fuse Protected

The control system is protected by a fuse to prevent excessive current draw which could damage the system. If operation does not resume after a cooling period of one hour, contact Brewer 888-Brewer-1 (888-273-9371).

TABLE ADJUSTMENTS (continued)

Seat Back

The back can be adjusted to any angle between horizontal and 80°.

NOTICE

To Lower Backrest Fully

Table must be raised to a height of 28" before the backrest can be lowered to the horizontal position. (See Figure 43).

Pneumatic Manual Backrest (Models 6000 & 6001)

1. To lower the seat back, push down on the seat back while pulling the release handle upward.

CAUTION



Backrest Lowering Hazard

Depressing the manual backrest release handle while a patient is seated on the table can cause the backrest to lower rapidly. Lower the backrest in increments by depressing and releasing the handle. Allowing the backrest to lower in a single motion could cause injury to the patient.

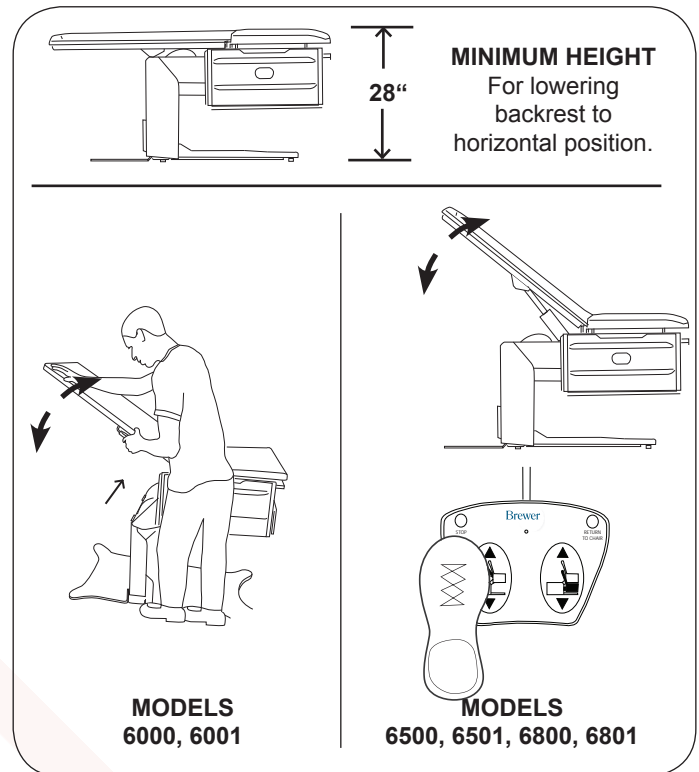

Figure 43. Adjusting Seat Back

2. To raise the seat back, place hand on the backrest to prevent it from rising rapidly, and then pull the release handle upward. The seat back will lock in the desired position when the handle is released.

NOTE: The pneumatic backrest cylinder does not exert enough force to raise the backrest with a patient lying on the table.

Powered Backrest (Models 6500, 6501, 6800 & 6801)

1. To lower the seat back, depress and hold the Back Down pedal until the desired angle is achieved, then release the pedal.
2. To raise the seat back, depress and hold the Back Up pedal until the desired angle is achieved, then release the pedal.

NOTICE

Power Back Actuator-Push Only

On power back models, the back is positioned by a "push only" actuator that raises the back. When lowered, the actuator retracts and gravity causes the back to lower.

NOTICE

Avoid Continuous Operation

The table's control system includes a thermal overload safety switch to protect from overheating. If the table is operated continuously causing the control to exceed its allowable operating temperature, the thermal overload safety switch will shut off. If normal operation ceases, do not attempt to operate the table. Allow the table to cool for 10-15 minutes before attempting to use again. The thermal overload switch will automatically reset when it has reached a safe operating temperature.

TABLE ADJUSTMENTS (continued)

Manual Pelvic Tilt

(Models 6001, 6501 and 6801)

The manual pelvic tilt feature sets the seat angle at 0° (horizontal) or 5° (up) position.

Pull up on the front of the seat and the pelvic tilt automatically travels to the locked tilt position (Figure 44).

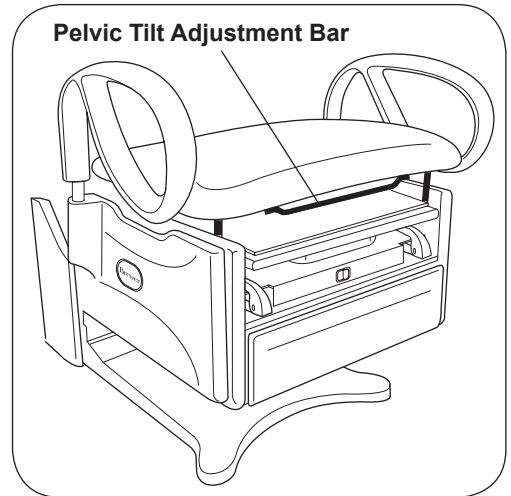

Figure 44. Pelvic Tilt Adjustment

NOTICE

Engaging the Pelvic Tilt Mechanism

Pulling up with excessive force can damage the pelvic tilt mechanism. Lift only with enough force to engage mechanism.

To lower seat, lift the adjustment lever and lower the seat to the horizontal position.

NOTICE

Lowering the Pelvic Tilt Mechanism

Patient must be removed from table prior to lowering the pelvic tilt mechanism.

Front Drawer Warmer

(Models 6001, 6501 and 6801)

Models 6001,6501 and 6801 are equipped with a drawer warmer that is turned on by a switch located above the drawer (Figure 45).

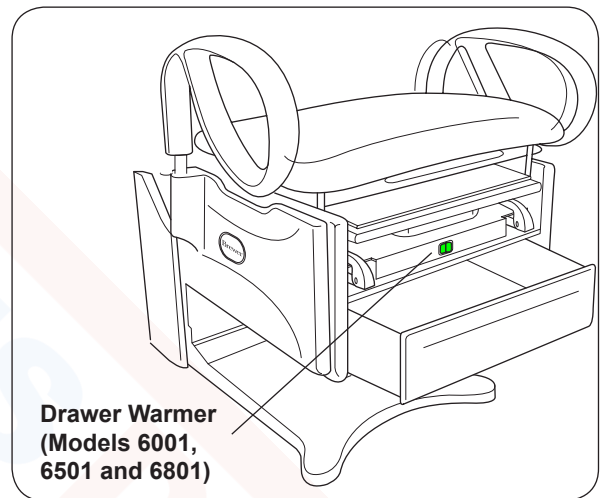

Figure 45. Front Drawer Warmer Switch

NOTICE

Proper Loading of the Front Drawer

Do not stack instruments in the front drawer. Place instruments in one layer in the bottom of the drawer.

Outlet

(Models 6001 (optional), 6501 and 6801)

Models 6001,6501 and 6801 are equipped with an Outlet (Figure 46). The maximum total load that can be plugged into the outlet is 2 amps.

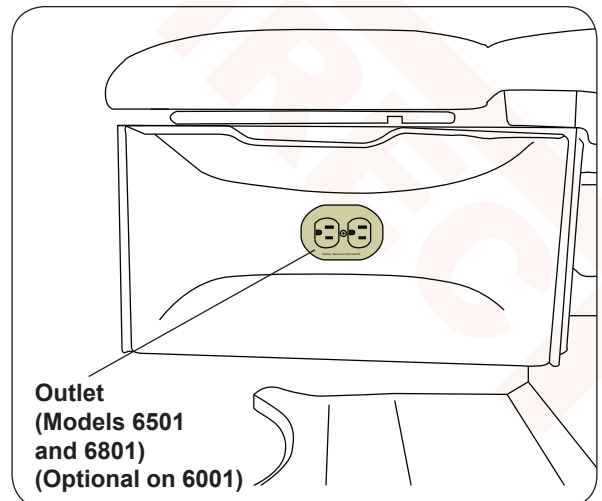

Figure 46. Table Outlet

NOTICE

Maximum Outlet Rating

Plugging a device into the outlet on the side of the table with rating higher than 2 amps may cause the fuse at the back of the table to blow.

MAINTENANCE

Preventative Maintenance

NOTICE

Loose Fasteners and Damaged Components

Failure to perform periodic inspections of the table could result in equipment damage.

- Inspect table every 6 months.
- Periodically inspect the electrical and foot control cords to ensure they are free of cuts or damage.
- Inspect the mechanical functions to ensure satisfactory operation.
- Check fasteners to make sure they are present and tightened securely.
- Lubricate moving parts (such as back and storage cover hinges) with a food grade silicon lubricant (Figure 47). Cover surrounding area to protect from overspray. Wipe away excess lubricant.

NOTICE

Table Malfunction

If table malfunctions, immediately remove your foot from the controls, unplug the power cord from the receptacle, and assist the patient from the table. Service the table prior to use.

Table Care

NOTICE

Wipe Spills Immediately!

The upholstery material is resistant to most medicinal type stains, but may be damaged by solvents and dyes. Remove any spilled fluids from the upholstery immediately.

For the latest in Cleaning Guidelines visit:
www.brewercompany.com

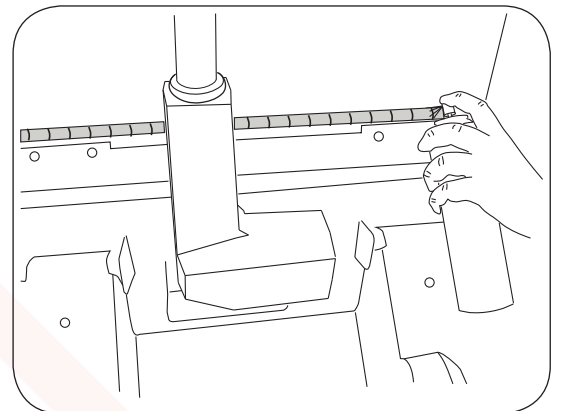

Figure 47. Lubricating the Backrest Hinge

SERVICE

WARNING



Shock Hazard
Disconnect power by removing plug from wall receptacle before servicing table.

Fuse Replacement

**Tables with Drawer Warmer and Outlet
(Models 6001 w/Outlet, 6501 and 6801)
(Figure 47)**

1. Unplug table from wall receptacle.
2. Fuse is located at the back of the table near the power cord.
3. Push the fuse holder cap in with a flat screwdriver and rotate 1/4 turn counterclockwise to remove cap and fuse.
4. Replace fuse with Brewer 2102490, 3A 250V fuse.
5. Push new fuse into cap.
6. Push cap with fuse into holder and rotate 1/4 turn clockwise to install.
7. Plug table into wall receptacle.
8. Check drawer warmer and outlet for proper function.



Figure 48. Tables with outlet and drawer warmer use a single 3A Fuse.

**Tables with Drawer Warmer Only
(Models 6001 without Outlet)
(Figure 48)**

1. Unplug table from wall receptacle.
2. Fuses are located at the back of the table near the power cord.
3. Push the fuse holder cap in with a flat screwdriver and rotate 1/4 turn counterclockwise to remove cap and fuse.
4. Replace fuses with Brewer 100777, 1A 250V fuse.
5. Push new fuse into cap.
6. Push cap with fuse into holder and rotate 1/4 turn clockwise to install.
7. Plug table into wall receptacle.
8. Check drawer warmer for proper function.



Figure 49. Tables with drawer warmer and no outlet use two 1A fuses.

WARRANTY

For Brewer Warranty Information:

Visit www.brewercompany.com or contact the Brewer Customer Service Department at (1-888-Brewer1).

ACCESSORIES

Listed below are the accessories which are authorized for use with this table.

Description	Order No.	Use/Restrictions
Urology Tray w/Hose & Bucket	100253	Conveniently and safely captures fluids during urology procedures.
Front Drawer Organizer	100407	Optional front drawer dividers for separation and organization.
Stainless Steel Treatment Pan	98464	Stainless Steel Treatment Pan for collecting debris and/or fluids during procedures.
Welch Allyn III Light Bracket (customer installed)	100881	For mounting of Welch Allyn III light.
Welch Allyn IV Light Bracket (customer installed)	102032	For mounting of Welch Allyn IV light.
Armrest Hole Cap	101872	Covers hole created when user chooses to remove grab bars.

The following items are required for the Articulating Knee Crutch accessory:

Deluxe Articulating Knee Crutches	99504	Allows leg positioning for ease of examination. Contains one LH and one RH Knee Crutch.
Knee Crutch Adapters (field install)	100550	Provides attachment point for Knee Crutch Clamps. Contains two Adapters.
Knee Crutch Clamp	99502	Clamps Knee Crutch to adapter. Contains one clamp.