

Brewer

FLEX Access
Exam Table

Installation & Operation Manual

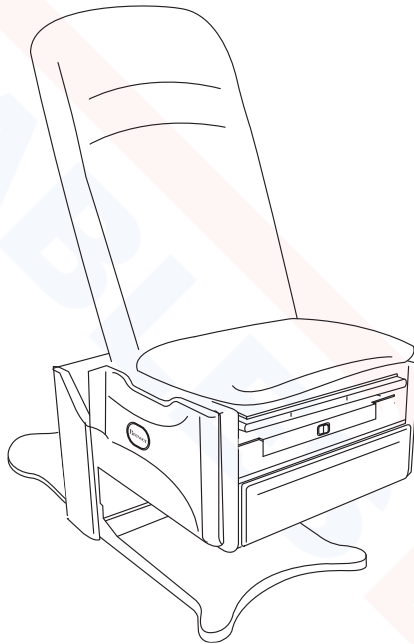

<i>Important Information</i>	2	<i>Table Adjustments</i>	17
<i>Safety Information</i>	3	<i>Maintenance</i>	20
<i>Component Identification</i>	3	<i>Service</i>	20
<i>Specifications</i>	4	<i>Options and Accessories</i>	22
<i>Installation</i>	5	<i>Common Service Parts</i>	23
<i>Operation</i>	11		

The Brewer Company, LLC
N88 W13901 Main Street, Suite 100
Menomonee Falls, WI 53051
P 1.888.Brewer.1
F 262.251.2332
www.brewercompany.com

IMPORTANT INFORMATION

General

Read and understand all operating instructions, safety information, and maintenance requirements contained in this manual prior to operating the table. Become familiar with all of the table functions before using it with a patient.

The Brewer Flex Access Exam Table Models 5700 and 5800 Series are designed to provide positioning and support of patients during general examinations conducted by qualified medical professionals. The Brewer Flex Access Exam Table is primarily used in examination rooms for general examinations and minor procedures. The wide variety of positions provided by one or two powered motions, and slide-out leg support create a safe and convenient patient positioning table for use in the doctor's office.

The table is easily adjusted to a wide variety of positions using the convenient foot control provided with the table. The table height can be adjusted from 18" to 37". The table seating surface on models 5701 and 5801 can be moved from the normal horizontal position to an angle of 5°. The backrest can be adjusted from a flat lying down position, to an 80° angle for seating.

In addition to the electronically controlled positions noted above, several manual adjustments are available:

Standard Features

- The SafeGlide™ leg support can be extended up to 21" for the patient prone position.
- A removable treatment pan is built-in underneath the leg support pad for use during examinations.
- A storage drawer at the front of the table may be used for supplies.

Optional Features

- Stirrups - may be manually extended through infinite positions and four lateral positions.
- Grab bars - attached to each side of the table may be rotated out of position or removed for improved access to the patient.
- Pass through work surface - stored under the seat, may be pulled out from either side of the table.

Service

If you require assistance with the installation or operation of your Brewer table, call the Brewer Customer Service Department at **(1-888-Brewer1)**. Our trained staff will attempt to assist you in correcting the problem directly over the phone. If service is required, a factory authorized technician will be sent to your location.

Please fill in the following information for use when calling the Brewer Company or your distributor with questions regarding your unit.

Date of Purchase _____

Serial Number _____

Model Number _____

Authorized Dealer Name _____

Dealer Phone Number _____

Dealer Address _____

SAFETY INFORMATION

Safety Information

The primary concern of The Brewer Company is that the equipment is operated and maintained with the safety of the patient and healthcare staff in mind. To ensure safe and reliable operation:

- Read and understand all instructions in this manual before attempting to install or operate the unit.
- Ensure that appropriate personnel are informed on the manual contents. This is the responsibility of the purchaser.
- Ensure that this manual is located near the table, or if possible, permanently affixed to the table.



This is the safety alert symbol. It is used to alert you to potential physical injury hazards. Obey all safety messages that follow this symbol to avoid possible injury or death.



DANGER Indicates a hazardous situation that, if not avoided, will result in death or serious injury.



WARNING indicates a hazardous situation which, if not avoided, could result in death or serious injury.



CAUTION indicates a hazardous situation which, if not avoided, could result in minor or moderate injury.

COMPONENT IDENTIFICATION

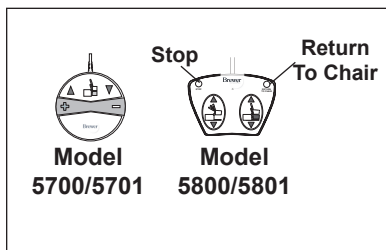
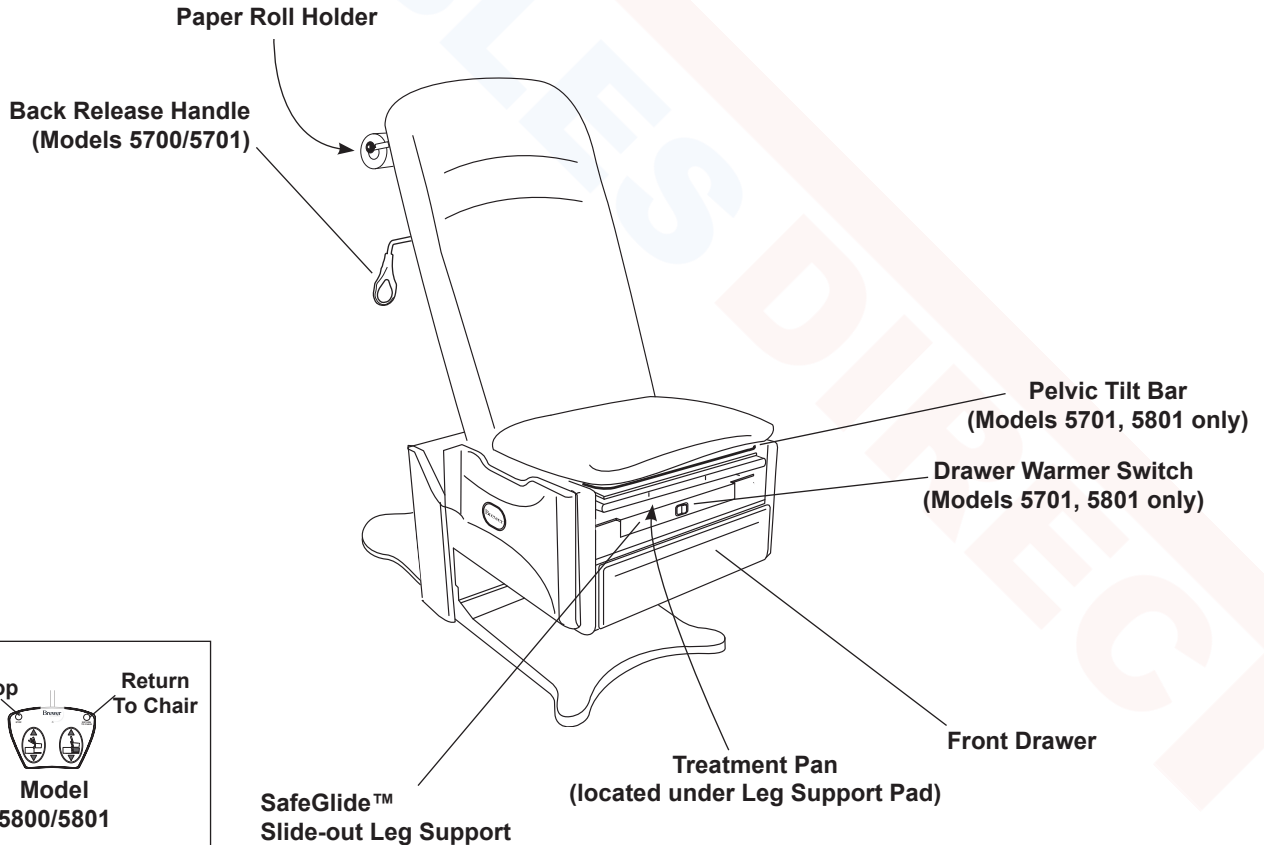

Foot Controls

Figure 1. Component Overview

SPECIFICATIONS

Weight of Table 315 lbs

Load Rating (maximum)

- Seat/Back 5700/5701/5800/5801 700 lbs.
- Leg Support 50 lbs.
- Pass Through Work Surface (optional) 15 lbs.
- Grab Bars (optional) 100 lbs.

Range of Motion

- Back Section Range 0° (horizontal) to 75-85°
- Table Top Height Range 18 ± 0.5 in. to 37 ± 1.0 in.
- Pelvic Tilt Range
(Models 5701 & 5801 Only) 0° (horizontal) to 5° (up)

Upholstery Dimensions

- Upholstered Top 24 to 28 in. wide x 60 in. long
- Upholstered Leg Support 18 in. long x 18 in. wide
- Overall Length of Upholstery 60 in. long
- Upholstery with Leg Support Extended 78 in. long

Electrical Rating

- 5700/5800 115 VAC nominal, 60 HZ, 6.0 amps
- 5701/5801 W/Outlet 115 VAC nominal, 60 HZ, 6.0 amps
- Fuse Rating:
- Control Box Fuse Rating 250V/2.5A
- Option/Warmer & Outlet Fuse Rating 250V/3.0A
- Outlet Max Load 2.0A

Duty Cycle (10%)

..... 2 minutes on / 18 minutes off (motor run time)

Power Cord

- Length Extends 70 in. from Table
- Type Detachable
- Conductors 18 AWG / 3 Conductor
- Grade Hospital Grade Plug

Type of protection against electrical shock

- Model 5700 and 5800 Class 2 Double Insulated
- Models 5701 and 5801 Class 1 Grounded
- Patient applied parts (all models) Type B

Type of protection against ingress of water Ordinary

Paper Roll Sizes

- Regular 18 in. x 3.5 in.
- Long 21 in. x 3.5 in.

Certifications* UL60601-1; CAN-CSA C22.2 No. 601.1

Operating Conditions

- Temperature Range 65° to 85°F
- Relative Humidity 10% to 90%

Transportation and Storage

- Temperature -20°F to 150°F
- Humidity 10% to 90%

*  Classified in the United States and Canada per the standards listed above.

NOTICE

Certifications

This product has been evaluated with respect to electrical shock, fire, and mechanical hazards only in accordance with UL60601-1; CAN/CSA C22.2 No. 601.1

NOTICE

Electromagnetic Interference (EMI)

This product is designed and built to minimize electromagnetic interference with other devices; however, if interference is noticed between another device and this product, remove the interfering device from the room or plug this product into an isolated circuit.

Model Configurations

Model	Power Back	Pneumatic Manual Back	Pelvic Tilt	Drawer Warmer	Return To Chair	Outlet
5700		X				
5701		X	X	X		X
5800	X				X	
5801	X		X	X	X	X

INSTALLATION

NOTICE

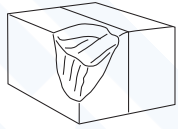

Inspect Carton and Contents

Inspect all boxes and contents for damage. Report any damage to the carrier immediately.

NOTICE



No Sharp Tools

To avoid damaging the table's upholstery or painted surfaces, DO NOT use a knife or other sharp object to open the packaging.

NOTICE

Proper Handling

To avoid injury and damage to the table, handle only as indicated in Figures 2 through 16. Do not handle as shown in Figures 8 through 10.

NOTICE



Avoid Self Activation Damage

Plugging table into receptacle prior to the removal of all packaging materials, may cause damage if self activation occurs.

Overview

Perform the following sequence in order when setting up the table:

- Uncrating the table
- Leveling the table
- Adjusting Rear Base Extension
- Installing Power Cord
- Installing Foot Control
- Installing Grab Bars

Tools Required

Drill Driver, 7/16" socket bit, or 7/16" wrench, 9/16" wrench, #2 Phillips bit, side cutter and furniture dolly.

Uncrating

1. Remove stretch wrap surrounding table.
2. Remove the 4 steel shipping brackets securing the table to the pallet (Figure 2). The brackets hook onto the table levelers to hold the table securely to the pallet. Remove the 2 bolts from each bracket using a 7/16" socket or wrench. Take care not to scratch the unit when using the driver or turning the wrench. Remove brackets from levelers once bolts are removed.
3. Remove the 2 screws attaching the spacers on either side of the wooden U-shaped brace located under the front corners of the cabinet (Figure 3). Remove the 2 screws attaching the U-shaped brace to the pallet (Figure 3).

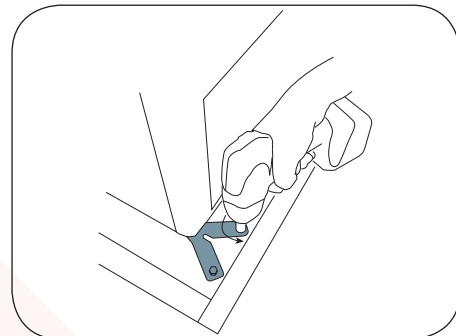

Figure 2. Remove Shipping Brackets

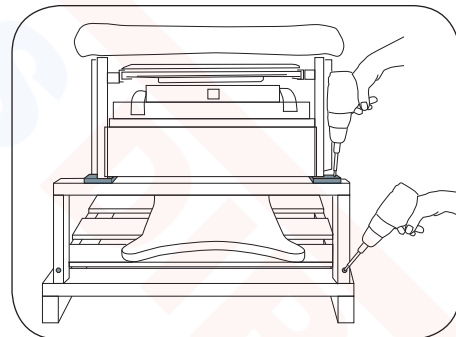

Figure 3. Remove Spacer and U-Brace Screws

NOTICE

Grab Bar Option

If your table was purchased with the Grab Bar option, remove the box from the back of the pallet.

INSTALLATION (continued)

NOTICE

In order to prepare the table for moving, you must power it up, and change the position from the position.

4. Cut the shipping strap, and discard strap and foam tube (Figure 4).
5. Make sure all shipping materials (except for wooden brace and spacers) and packing foam are removed from the table, pallet and surrounding area.
6. Remove the foot control and power cord from the front drawer after packing materials have been removed.
7. Insert the foot control cord into the receptacle at the bottom of the rear panel (Figure 5). Note: Make sure the tab on the plug is aligned with the slot in the receptacle. The plug may appear to be fully inserted and yet have some distance to go. Wiggle the foot control plug while pushing it in firmly to ensure that it is fully seated (Figure 6).
8. Remove the gray power cord from the front drawer.

NOTICE

Confirm Voltage and Plug Type

See **SPECIFICATIONS** table for electrical rating of this unit. The three-pronged grounding plug on the table power cord must be plugged into a matching three-pronged, grounded, non-isolated, correctly polarized 115 VAC receptacle.

9. Plug the power cord into the receptacle at the bottom of the rear panel (Figure 5). Plug the power cord into a 115 Volt grounded receptacle.

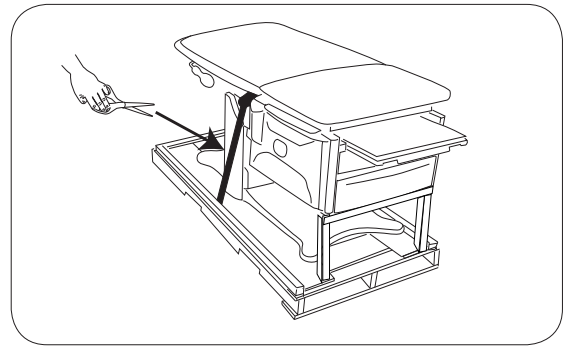

Figure 4. Cut Shipping Strap

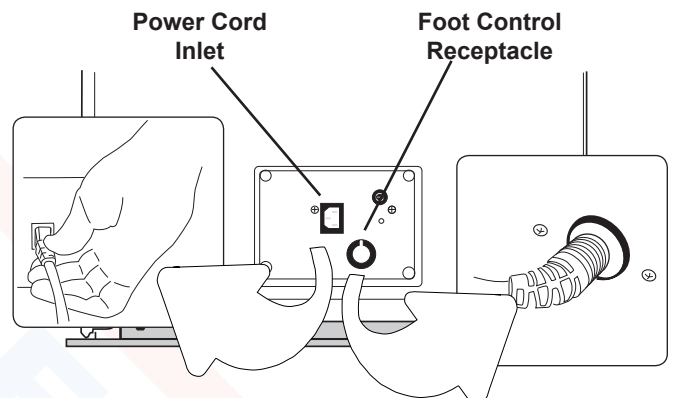

Figure 5. Power Cord and Foot Control Plug-ins

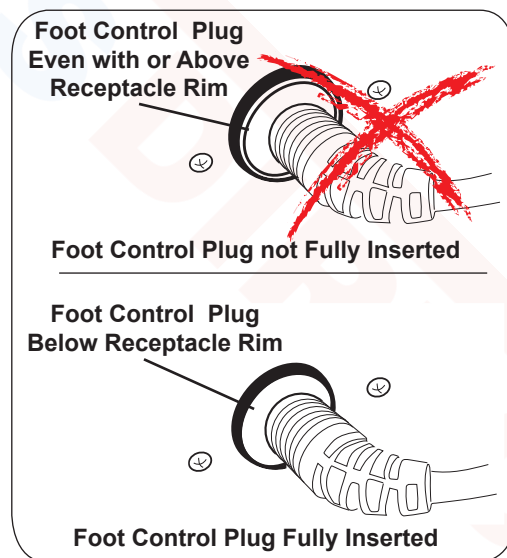

Figure 6. Foot Control Properly Pugged In

INSTALLATION (continued)

11. Press lift up on the foot control to raise the seat approximately 1" (Figure 7).

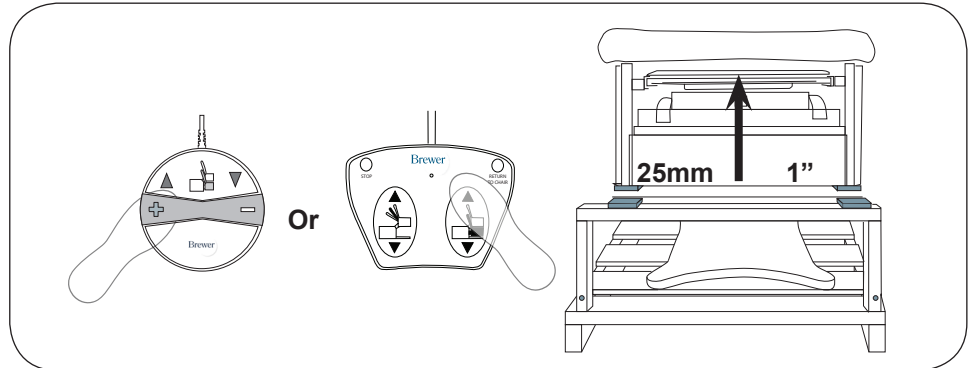

Figure 7. Raise Seat off of Brace

To aid in preventing injury or product damage please observe the following cautions when removing the table from the pallet.

NOTICE

Avoid Pelvic Tilt and Upholstery Damage

Do not lift or move table by pulling up on the seat upholstery (figure 8). Lifting by the seat will damage the pelvic tilt mechanism (if equipped) and may damage the upholstery.



Figure 8. DO NOT Lift by Upholstery

NOTICE

Avoid Backrest Actuator and Upholstery Damage

Never push forward on the backrest to move table. Pushing on the backrest will cause backrest actuator damage and may cause upholstery damage (figure 9).



Figure 9. DO NOT Push on Backrest

NOTICE

Avoid Stirrup Damage

Do not lift or move table by using the stirrups as a hand hold. Lifting or moving table by stirrups can damage the internal indexer housing unit (Figure 10).

WARNING

Lifting Hazard

The table weighs approximately 315 lbs. Use enough personnel to remove the table from the shipping pallet. Use proper lifting techniques. Failure to do so could result in serious injury.

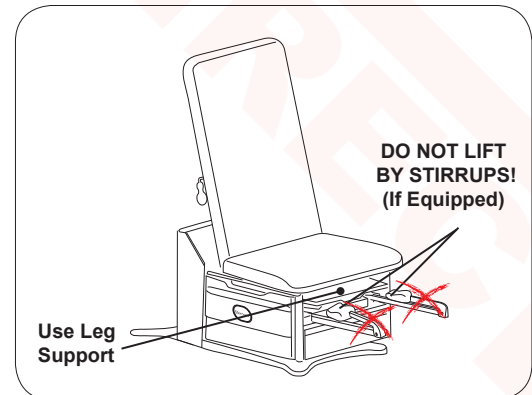

Figure 10. DO NOT lift by Stirrups

INSTALLATION (continued)

12. Raise the backrest to its full up position (Figure 11).

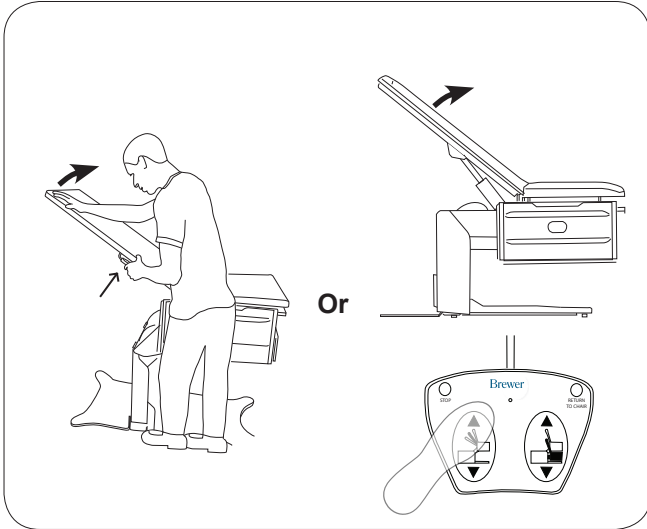

Figure 11. Raise Backrest

13. Unplug foot control and power cord and place into front storage drawer (Figure 12.).

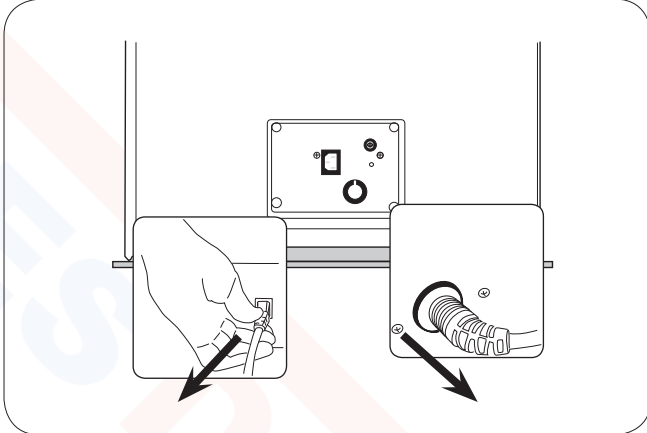

Figure 12 Unplug Foot Control and Power Cords

14. Tilt table slightly to place the (4) slides under levelers (Figure 13).

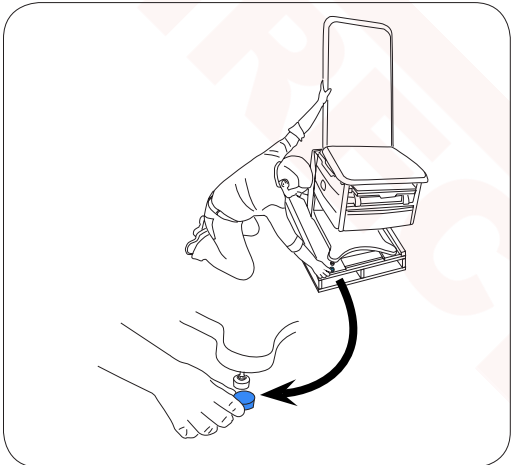

Figure 13. Installing Leveler Slides

INSTALLATION (continued)

15. Slide table partially off of pallet and stop when there is sufficient room to place furniture dolly beneath base of table. Finish pulling table onto furniture dolly (Figure 14).

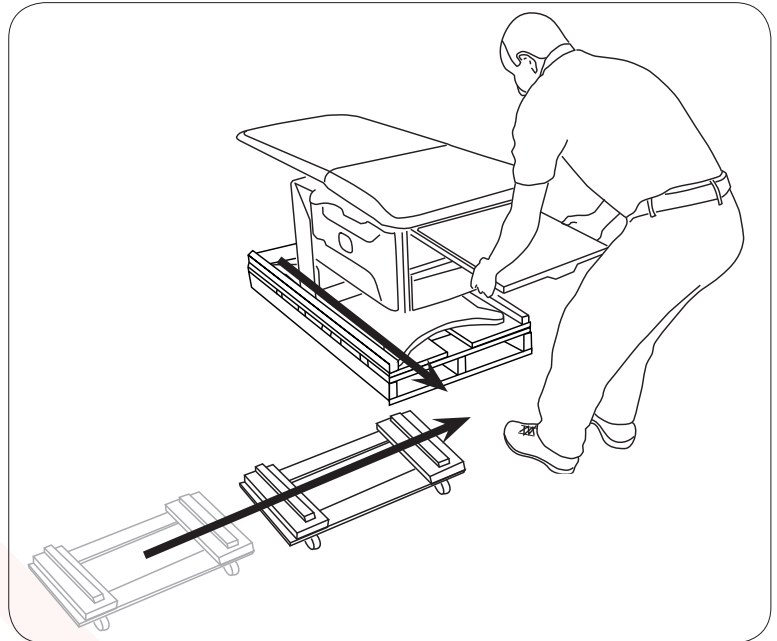

Figure 14. Slide table off of pallet

Leveling the Table

A leveling screw pad (Figure 15) is located in four places under the table's base. Adjust the four leveling pads to achieve a solid, level installation.

NOTICE

Prevent Leveler Damage

Levelers must remain in the table, and be fully engaged a minimum of (3) turns. If levelers are not fully engaged in the base, damage to the threading in the base and/or leveler can occur.

NOTICE

Prevent Floor Damage and Unwanted Table Movement

Make sure the rubber caps are present on all (4) levelers. Missing caps can allow the table to slide, and the exposed metal portion of the leveler can damage flooring.

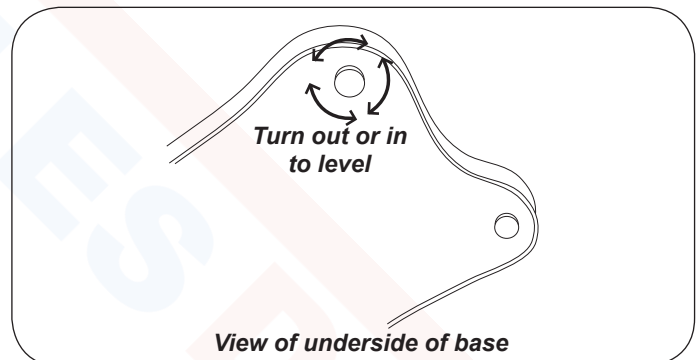

Figure 15. Leveling Screw Pad (located under table)

Adjusting the Rear Base Extension

After leveling the table, the Rear Base Extension should be brought into contact with the floor (Figure 16).

1. Loosen the two Rear Base Extension adjusting screws.
2. Lower plate until it contacts the floor.
3. Tighten the two Rear Base Extension adjusting screws.

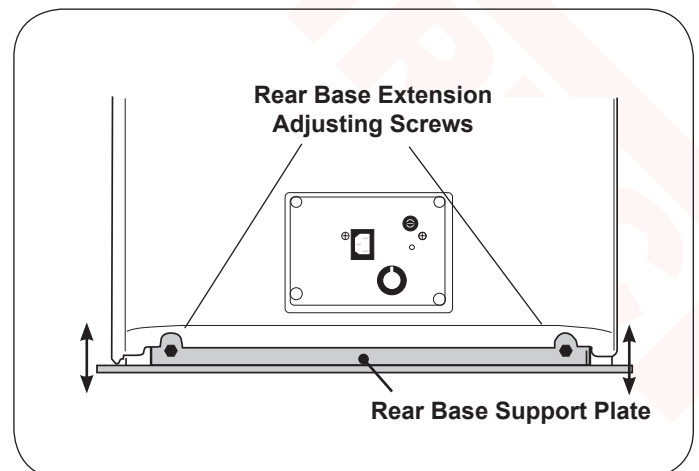

Figure 16 Adjusting the Rear Base Extension

INSTALLATION (continued)

Installing the Power Cord

1. Remove the power cord from the front drawer.
2. Insert the female plug end of the power cord into the receptacle on the table (Figure 17). Make sure the plug is fully seated.

Installing the Foot Control

1. Remove the foot control from the front drawer.
2. Insert the male plug of the foot control cord into the receptacle on the table (Figure 17). Make sure the plug is fully seated. See Figure 6 for proper insertion of the foot control plug. Failure to properly insert the foot control plug can cause some functions to not operate properly.

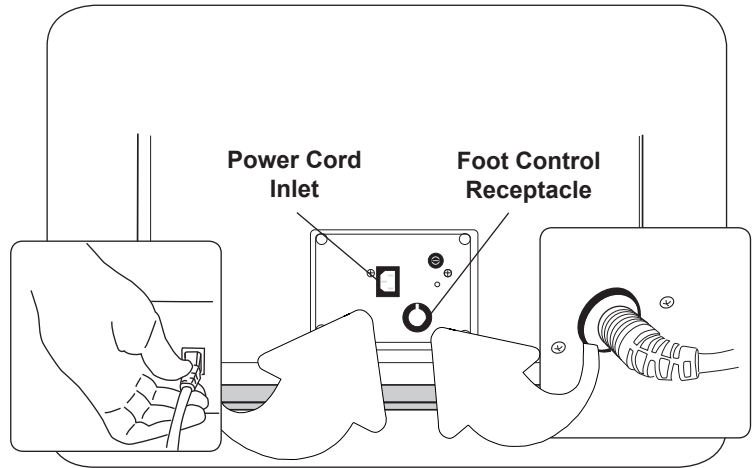

Figure 17 Foot Control and Power Cord Receptacles

Installing Grab Bars (Optional)

1. Remove grab bars from the carton banded to the pallet.
2. Grab bars are interchangeable and may be installed on either side.
3. Align pin on grab bar shaft with mating slot on side of table. See Figure 18.
4. Push grab bar all the way down and rotate to front of table.
5. Push grab bar down until it engages to prevent left or right movement.

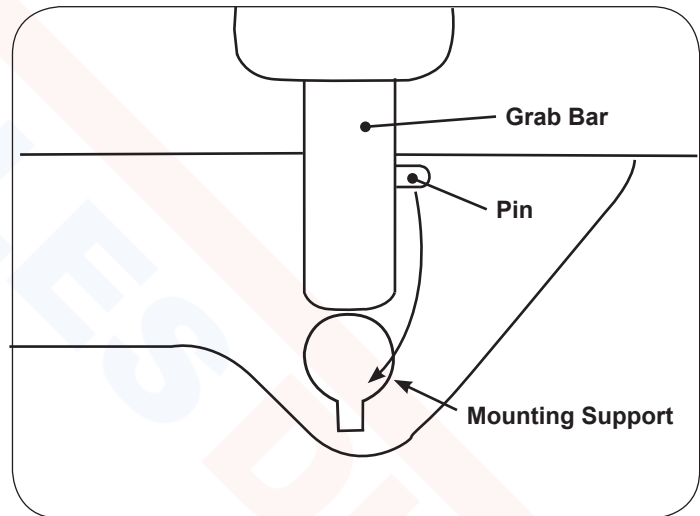

Figure 18. Grab Bar

OPERATION

WARNING



Explosion/Fire Hazard
Do not use this table in an explosive or oxygen rich atmosphere. Failure to do so may result in serious personal injury or death.

WARNING

Table Malfunction Hazard

If table malfunctions, immediately remove your foot from the controls, unplug the power cord from the receptacle, and assist the patient from the table. Service the table prior to use. Continuing to use a malfunctioning table may result in patient or personal injury, or product damage.

WARNING

Area Not Clear Hazard

Before initiating power keep personnel and equipment clear of table before initiating movement to avoid personal injury or damage to the equipment.

WARNING



Shock Hazard

When performing cauterization or similar treatment, the patient must be insulated from the metal portions of the table by non-conductive material. Failure to do so may result in electrical shock.

WARNING



Explosion/Fire Hazard

Do not use this table in an explosive or oxygen rich atmosphere. Failure to do so may result in serious personal injury or death.

CAUTION

Unintended Operation

Keep foreign objects away from foot control. To avoid accidental operation, be sure the foot control is NOT positioned below the front of the table. Failure to do so could result in unwanted motion, injury and possible damage to the table.

NOTICE

Optimum Table Performance

For optimum table performance, allow the table to reach room temperature before operating.

NOTICE

Avoid Continuous Operation

The table's control system includes a thermal overload safety switch to protect from overheating. If the table is operated continuously causing the control to exceed its allowable operating temperature, the thermal overload safety switch will shut off. If normal operation ceases, do not attempt to operate the table. Allow the table to cool for 10-15 minutes before attempting to use again. The thermal overload switch will automatically reset when it has reached a safe operating temperature.

NOTICE

Fuse Protected

The control system is protected by a fuse to prevent excessive current draw which could damage the system. If operation does not resume after a cooling period of one hour, contact Brewer 800-558-8777.

NOTICE

Actuator Travel Limit Protection

Each control function will automatically stop moving when either the UP or DOWN travel limit is reached. If the foot pedal is pressed with travel at its limit, the actuator will not operate. Sensors prevent the actuator motor from operating when travel limit has been reached, preventing wear of the actuator.

NOTICE

Proper Power Supply

Do not use any power supply other than that listed on the rating label. Failure to do so may result in equipment damage.

NOTICE

Avoid Foot Control Damage

The foot control is moisture resistant and runs on low voltage, eliminating shock hazards. However, to avoid temporary or permanent damage to the foot control, do not immerse in water or liquids.

OPERATION (continued)

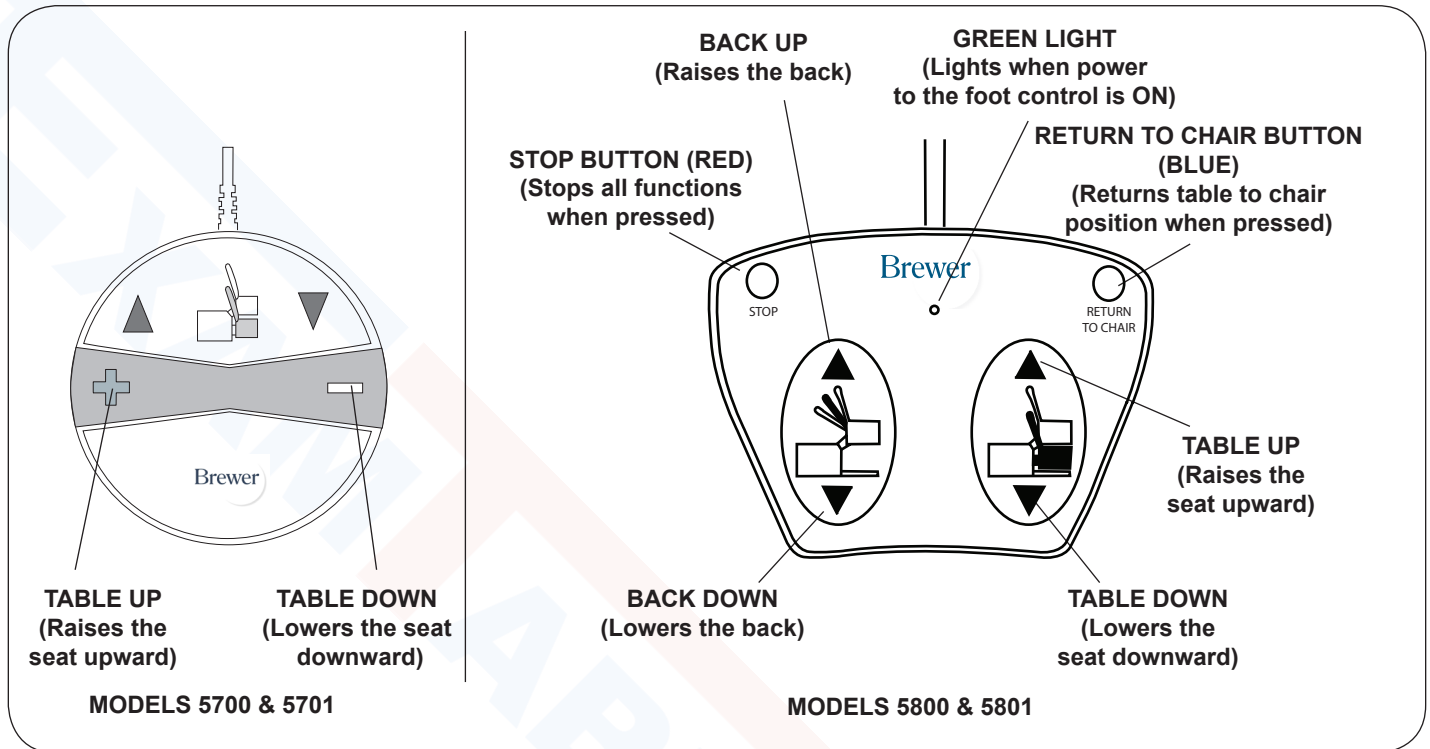

Figure 21. Foot Controls

Models 5700 & 5701

Models 5700 and 5701 are equipped with a single pedal foot control that controls the raising and lowering of the seat.

Models 5800 & 5801

Models 5800 and 5801 are equipped with a dual pedal foot control that controls the raising and lowering of the seat, and the raising and lowering of the seat back. In addition, the foot control features the following:

Return to Chair: When pressed, the table automatically returns to the low chair position. The seat back will rise to the full up position and the table will lower to the full down position and stop. If the Emergency Stop or either pedal is pressed while the table is in motion, the system will return to manual mode and all motion will stop.

Stop: When pressed, stops the Return to Chair function.

Green Light: (2 pedal foot controls only) indicates that there is power to the foot control.

NOTICE

Unattended Return to Chair Operation

Remain with and observe patient during Return to Chair operation. Return to Chair feature may need to be momentarily interrupted for patient to readjust him or herself, or for hazards to be removed before resuming motion. Press the Return to Chair button to resume motion only when patient has situated him or herself, or hazards have been removed.

OPERATION (continued)

Seat and Backrest Safety Switches

Seat Switch

All models are equipped with switches on the seat bottom (Figure 22) which automatically stops the lowering function of the seat if any of the switches comes into contact with an object as the seat is lowering. To continue lowering the seat, press up on the "TABLE UP" pedal (Figure 21), clear the obstruction, and continue lowering the seat.

Backrest Switch

All models are equipped with a switch on the top shroud (Figure 22) which automatically stops the lowering function of the seat and back if the switch is contacted by the backrest. To continue lowering the seat:

- **Models 5700 & 5701** Raise the backrest manually to clear the switch. When clear of the switch continue lowering the seat.
- **Models 5800 & 5801** - Depress the "BACK UP" pedal (Figure 21) to clear the switch. When clear of the switch continue lowering the seat.

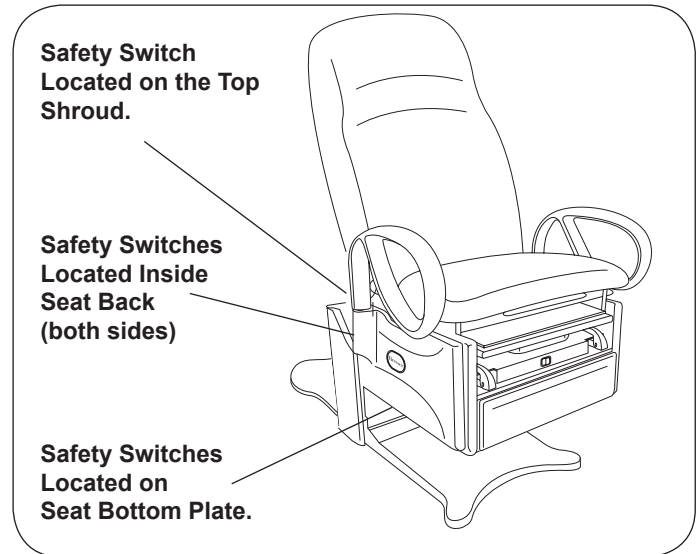

Figure 22. Seat and Backrest Safety Switches

SafeGlide™ Leg Support

The leg support is located under the seat cushion. (Figure 23). It can be extended 19" for the patient prone position. Pull leg support out to the fully extended position. To return the leg support to its stored position simply push the leg extension in.

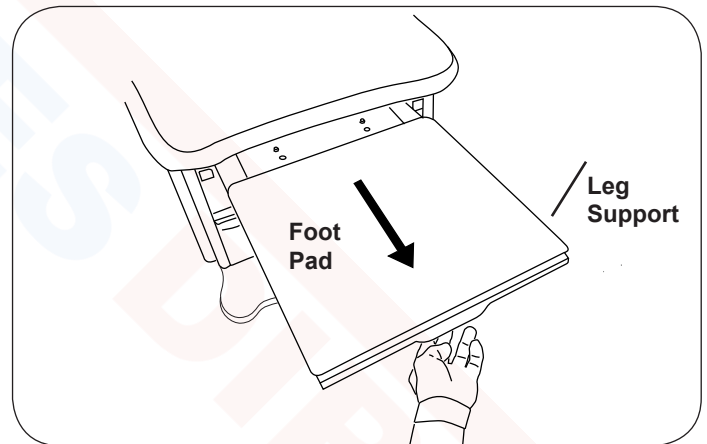

Figure 23. Leg Support Pull Out

⚠ CAUTION	
	<p style="text-align: center;">Fall Hazard</p> <p>The leg support is rated for 50 lbs and is not intended for use as a seat. Sitting on leg support could cause it to retract, bend, or cause the table to tip forward, creating a fall hazard leading to serious injury.</p>

The SafeGlide™ Leg Support comes with the leg support adjusted for the least amount of resistance. If you find it to glide too freely, the resistance can be increased by turning the thumbscrews (Figure 24) inward. Turn both thumbscrews the same number of turns inward or outward until the desired resistance is obtained.

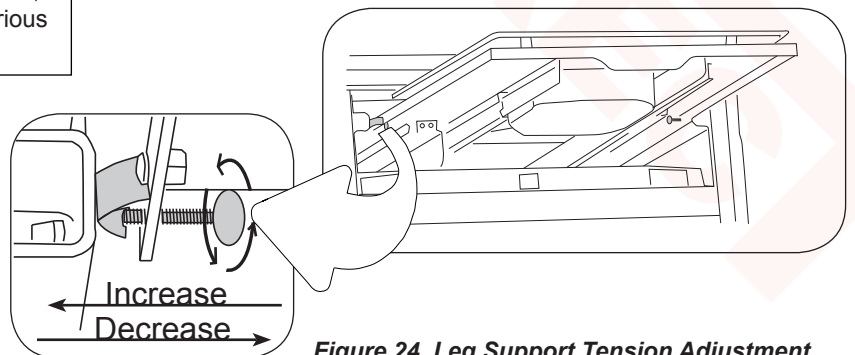

Figure 24. Leg Support Tension Adjustment

OPERATION (continued)

Foot Pad

The foot pad can be slid beneath the seat with the leg support extended for easy access to the treatment pan (Figure 25). Pushing the leg support back in will allow the glides on the foot pad to drop into slots. The foot pad will once again come out with the leg support the next time it is pulled out.

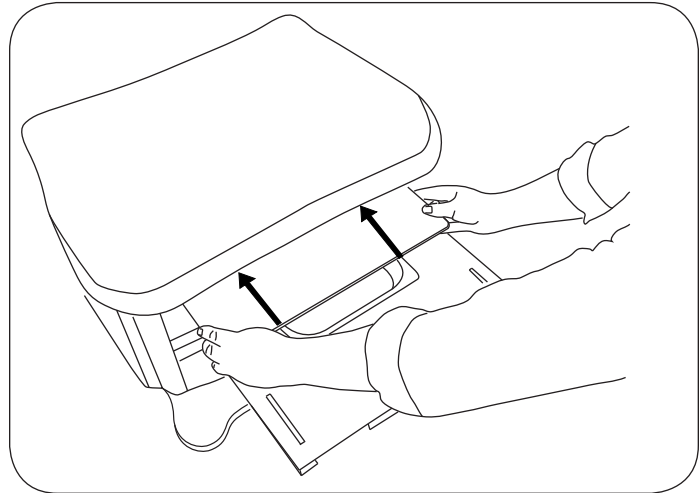

Figure 25. Slide Foot Pad Back

Treatment Pan

A removable treatment pan is built-in underneath the leg support pad for use during examination. Pull the leg support fully out and remove the leg support pad or slide it back under the seat (Figure 26) to access the pan (Figure 26). Remove the treatment pan for cleaning.

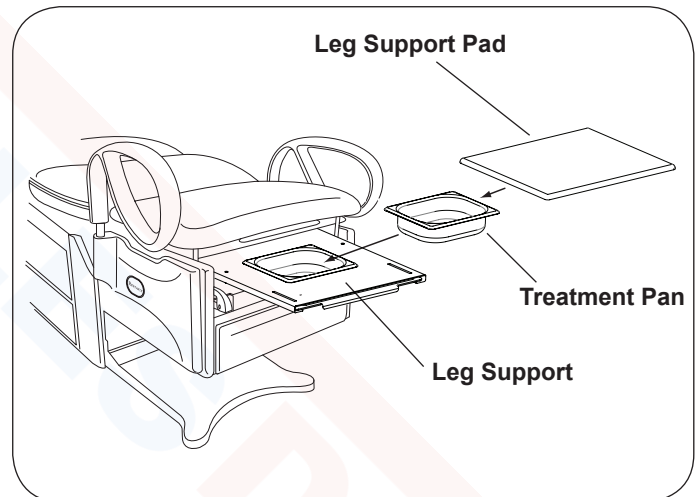

Figure 26. Treatment Pan

Front Drawer

A storage drawer for supplies is located at the front of the table. Models 5701 and 5801 are equipped with a drawer warmer that is turned on by a switch located above the drawer (Figure 27).

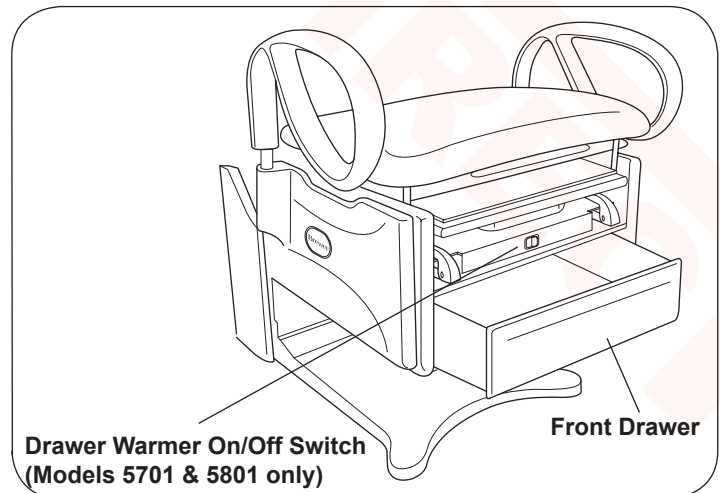

Figure 27. Drawer Warmer Switch and Front Drawer

OPERATION (continued)

Paper Roll Holder

To change a paper roll, remove old paper roll tube, place the paper holder rod into the paper roll tube, and place into paper holder "J-Hooks" located on the rear of the seat back (Figure 28). Pull the end of the roll over the top of the seat back and place in the desired position.

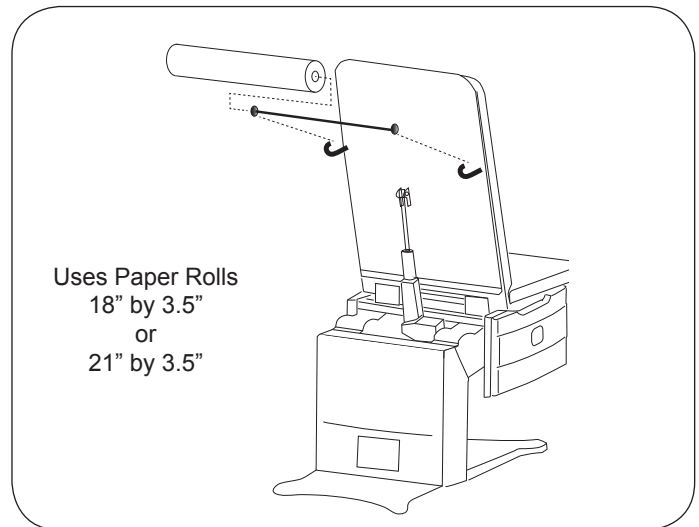

Figure 28. Paper Roll Installation

Pass Through Work Surface (Optional)

A pass through work surface, stored under the seat (Figure 29), may be pulled out from either side of the table. Grasp the edge of the work surface and pull until it is fully extended. Push it fully in to stow after use.

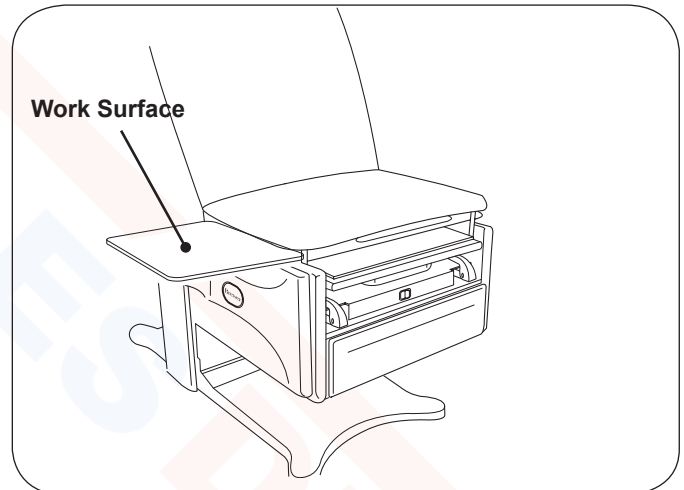



Figure 29. Pass Through Work Surface

 CAUTION	
	<p style="text-align: center;">Fall Hazard</p> <p>The work surface is rated for 15 lbs. and is not intended for use as a seat. Sitting on work surface could cause it to bend or break or cause the table to tip creating a fall hazard leading to injury.</p>

Removing the Work Surface for Cleaning

1. Push work surface in, to reveal a white plastic stop screw.
2. Remove the white plastic screw (Figure 30).
3. Pull the work surface toward you and remove it.
4. Reinsert screw after replacing work surface.

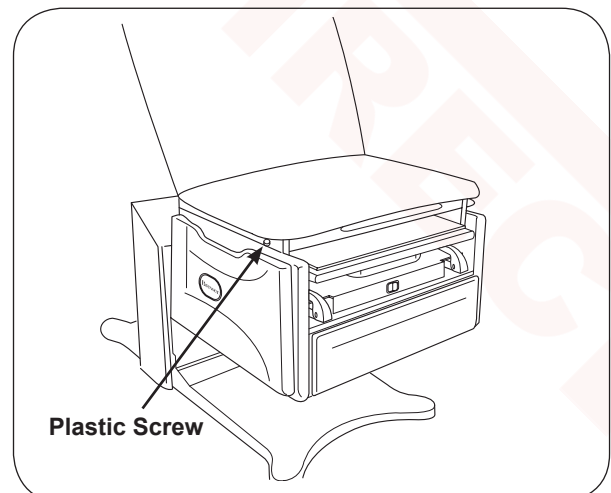

Figure 30. Location of White Plastic Stop Screw

OPERATION (continued)

Adjustable Stirrups (Optional)

Operating the Stirrups (Figure 31)

1. To operate the stirrups, grasp end of stirrup and pull straight out of the table. Lift up slightly while sliding the stirrup out.

NOTE: Applying downward pressure when pulling stirrup from table may make it difficult to move. Resistance is normal and is part of the stirrup friction locking mechanism.

2. Unfold stirrup upward to the fully open position.
3. Adjust the stirrup to the desired length by sliding it in or out.

Stirrup Lateral Adjustment

1. Lift end of stirrup slightly and then rotate outward to desired position.
2. When the desired position is achieved, lower the stirrup to engage the lateral locking mechanism (Figures 31 and 32).
3. Check that lateral locking mechanism is engaged by attempting to move stirrup assembly side-to-side without lifting on the stirrup end.

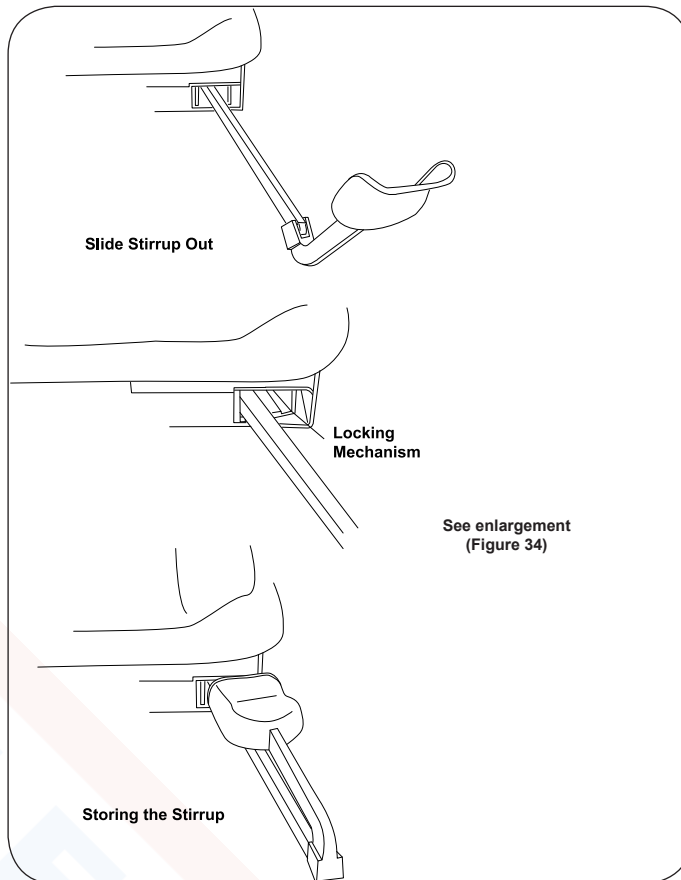

Figure 31. Stirrups

CAUTION	
	<p>Fall Hazard</p> <p>Failure to engage the lateral locking mechanism could allow patient to lose balance resulting in personal injury to patient (Figures 31 and 32).</p>

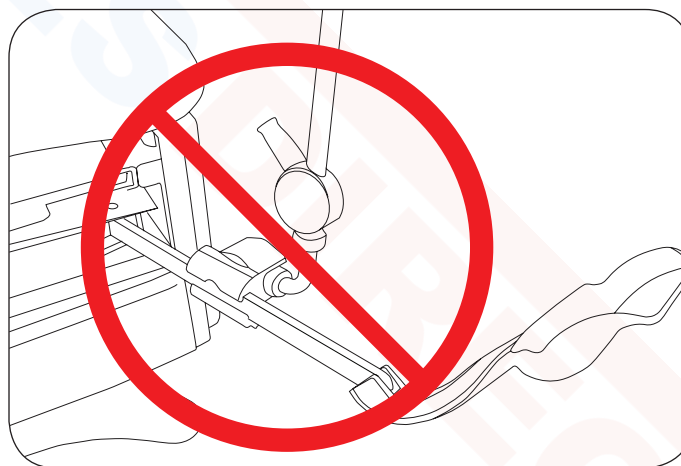

Figure 33. Affix No Attachments!

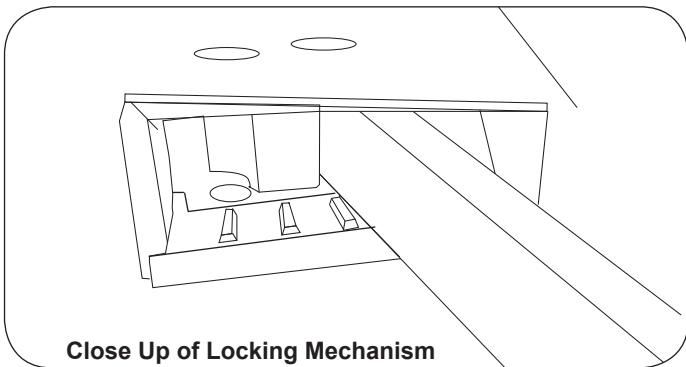

Figure 32. Stirrup Locking Mechanism

Storing the Stirrups

1. To store the stirrups in the table, grasp end of stirrup and pull straight out to its full extension.
2. Fold stirrup down against bar, then rotate it to the inner most lateral position and slide it back into the stowed position.

NOTICE
<p>Use Stirrup Only as Designed</p> <p>Do not use any part of the stirrup for attachment of any device (Figure 33). Warranty will be voided. If knee crutches are required for use, order mounting adapters and clamps shown on last page.</p>

OPERATION (continued)

Grab Bars (Optional)

In the forward (normal use) position the grab bars lock into place preventing left or right rotation.

The grab bars can be rotated to the side of the table for improved access to the patient. Pull up on the grab bar and rotate to the desired position. The grab bar locks in the front and rear position (Figure 34).

The grab bar can be removed from the table by pulling up on the grab bar, rotating it to the 90° position, and then lifting it out of it's holder.

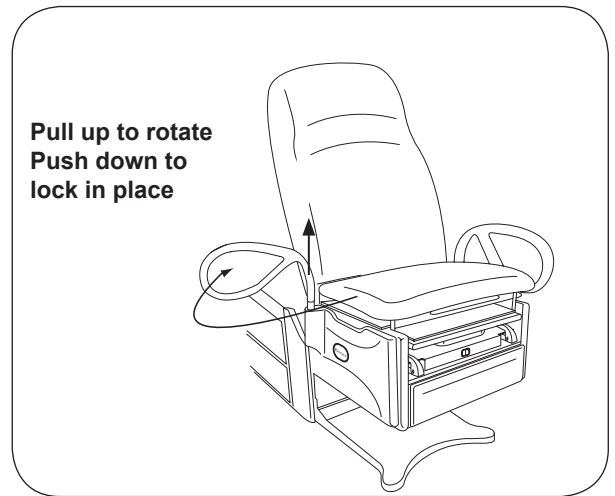

Figure 34. Grab Bar Adjustment

TABLE ADJUSTMENTS

Table Height

The table can be adjusted to any height between 18" to 37" (Figure 36).

1. To raise the table, depress and hold the Table Up pedal until the desired height is achieved, then release the pedal.
2. To lower the table, raise the backrest to the upright position, then depress and hold the Table Down pedal until the desired height is achieved, then release the pedal, or press the Return to Chair button (Figure 35).

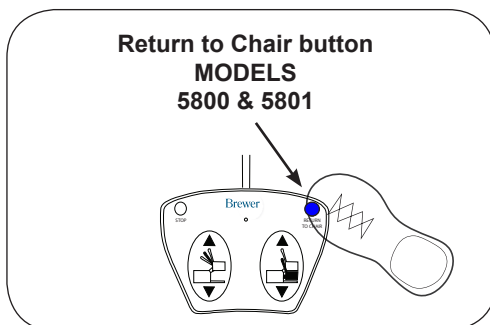

Figure 35. Lowering with Return to Chair

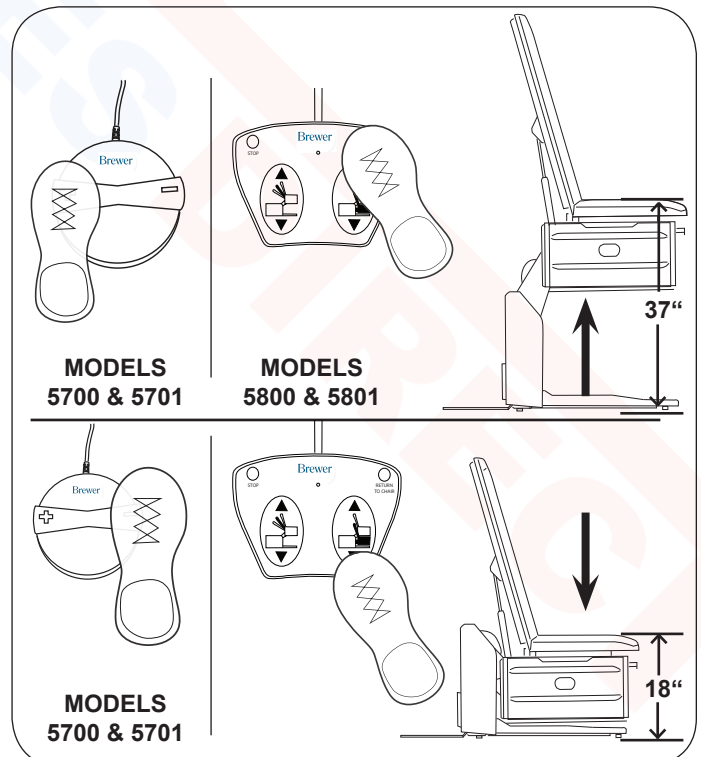

Figure 36. Table Height Positioning

TABLE ADJUSTMENTS (continued)

Seat Back

The back can be adjusted to any angle between horizontal and 80°.

CAUTION



Backrest Lowering Hazard

Depressing the manual backrest release handle while a patient is seated on the table can cause the backrest to lower rapidly. Lower the backrest in increments by depressing and releasing the handle. Allowing the backrest to lower in a single motion could cause injury to the patient.

NOTICE

To Lower Backrest Fully

Table must be raised to a height of 28" before the backrest can be lowered to the horizontal position. (See Figure 37).

Pneumatic Manual Backrest (Models 5700 & 5701)

1. To lower the seat back, push down on the seat back while pulling the release handle upward.
2. To raise the seat back, place hand on the backrest to prevent it from rising rapidly, while pulling the release handle upward. The seat back will lock in the desired position when the handle is released.

NOTICE

Power Back Actuator-Push Only

On power back models, the back is positioned by a "push only" actuator that raises the back. When lowered, the actuator retracts and gravity causes the back to lower.

Powered Backrest (Models 5800 & 5801)

1. To lower the seat back, depress and hold the Back Down pedal until the desired angle is achieved, then release the pedal.
2. To raise the seat back, depress and hold the Back Up pedal until the desired angle is achieved, then release the pedal.

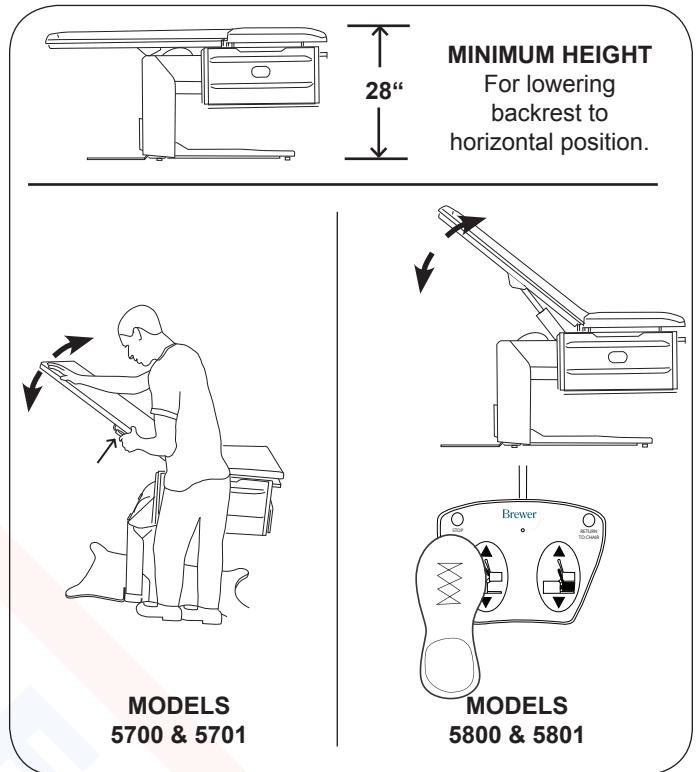

Figure 37. Adjusting Seat Back

TABLE ADJUSTMENTS (continued)

Manual Pelvic Tilt (Models 5701 and 5801)

The manual pelvic tilt feature sets the seat angle at 0° (horizontal) or 5° (up) position.

Pull up on the front of the seat and the pelvic tilt automatically travels to the locked tilt position (Figure 38).

NOTICE

Engaging the Pelvic Tilt Mechanism

Pulling up with excessive force can damage the pelvic tilt mechanism. Lift only with enough force to engage mechanism.

NOTICE

Lowering the Pelvic Tilt Mechanism

To lower seat, lift the adjustment lever and lower the seat to the horizontal position. Patient must be removed from table prior to lowering the pelvic tilt mechanism.

Front Drawer Warmer (Models 5701 and 5801)

Models 5701 and 5801 are equipped with a drawer warmer that is turned on by a switch located above the drawer (Figure 39).

NOTICE

Proper Loading of the Front Drawer

Do not stack instruments in the front drawer. Place instruments in one layer in the bottom of the drawer.

Outlet (Models 5701 and 5801)

Models 5701 and 5801 are equipped with an Outlet (Figure 40). The maximum total load that can be plugged into the outlet is 2 amps.

NOTICE

Maximum Outlet Rating

Plugging a device into the outlet on the side of the table with rating higher than 2 amps may cause the fuse at the back of the table to blow.

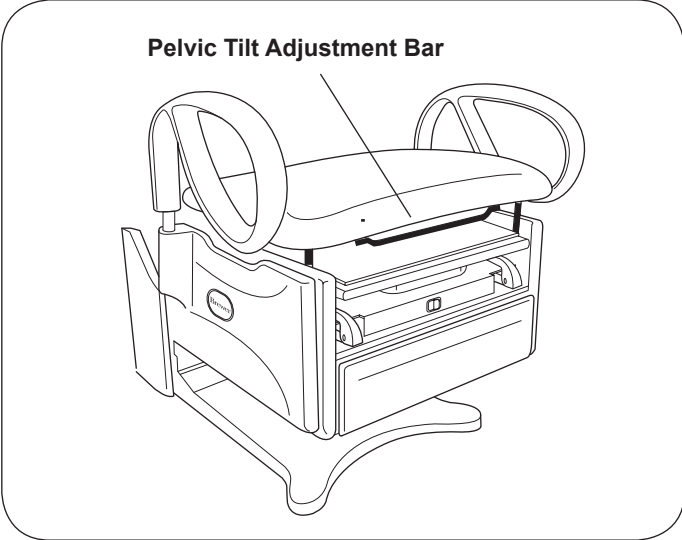

Figure 38. Pelvic Tilt Adjustment

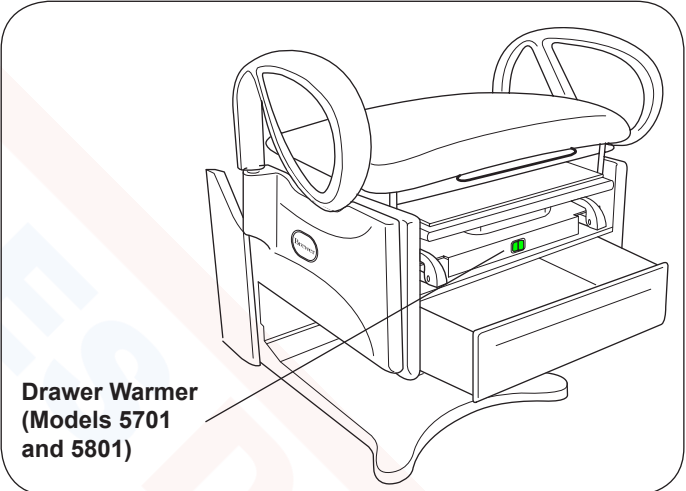

Figure 39. Front Drawer Warmer Switch

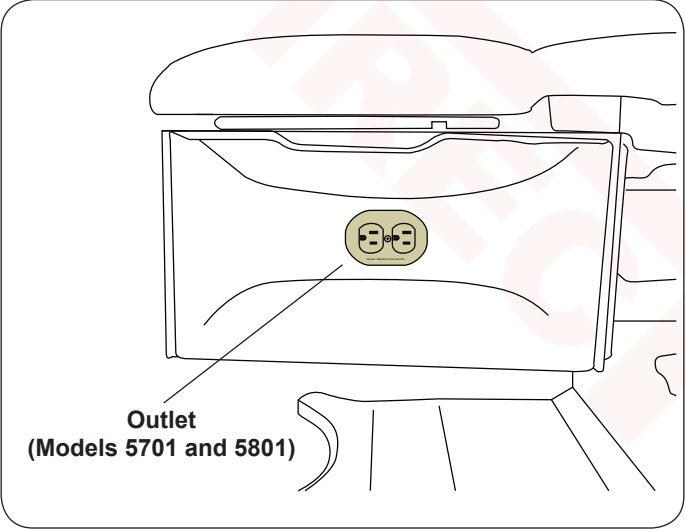

Figure 40. Table Outlet

MAINTENANCE

Preventative Maintenance

CAUTION

Loose Fasteners and Damaged Components Hazard
Failure to perform periodic inspections of the table could result in personal injury or equipment damage.

- Inspect table every 6 months.
- Periodically inspect the electrical and foot control cords to ensure they are free of cuts or damage.
- Inspect the mechanical functions to ensure satisfactory operation.
- Check fasteners to make sure they are present and tightened securely.
- Lubricate the backrest hinge with a food grade silicon lubricant (Figure 41). Cover surrounding area with cloth to protect from overspray and wipe excess.

Table Care

For the latest in Cleaning Guidelines visit:
www.brewercompany.com

NOTICE

More Cleaning Instructions Available
For the latest in Cleaning Guidelines visit:
www.brewercompany.com

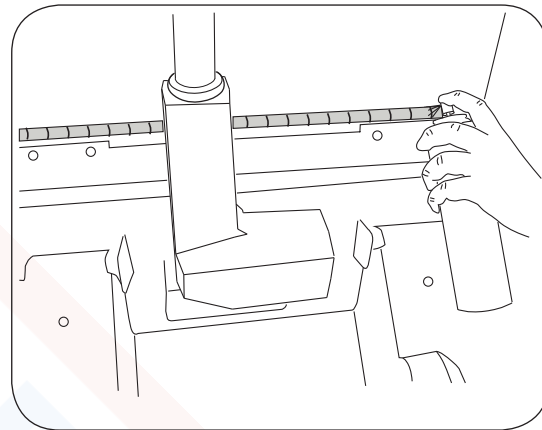

Figure 41. Pelvic Tilt Adjustment

SERVICE

Drawer Warmer Fuse Replacement (Models 5701 and 5801)

1. Disconnect power cord.
2. Remove fuse cap from back of table near the power cord (Figure 42).
 - a. Insert flat bladed screwdriver into slot.
 - b. Push in and turn counterclockwise 1/4 turn.
 - c. Pull cap/fuse from holder.
3. Replace fuse. Fuse type is 5 x 20mm, 250V/3.0A.
 - a. Insert replacement fuse in cap.
 - b. Insert cap/fuse into holder.
 - c. Push and twist 1/4 turn clockwise with screwdriver to lock.
4. Connect power cord and check drawer warmer for proper operation.

WARNING



Shock Hazard

Disconnect power by removing plug from the wall receptacle before changing fuses.

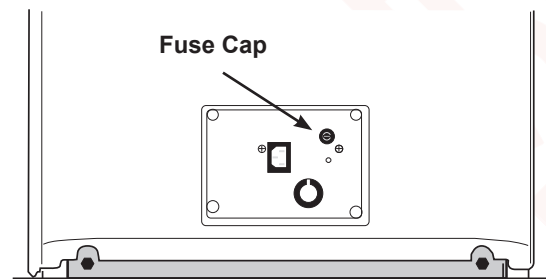



Figure 42.

Control Box Fuse Replacement (for tables with the seat in the up position)

⚠ WARNING	
	Shock Hazard Disconnect power by removing plug from the power outlet before changing fuses.

1. Manually raise table and prop in raised position using a support device intended for this purpose. (See Figure 43). *NOTE: Your support device may vary from example.*
2. Remove shroud below seat to expose actuators and control box. (See Figure 44.)
3. Locate fuse cover on control box. (See Figure 45.)
4. Pull out fuse cover with pliers.

⚠ WARNING	
	CRUSH HAZARD Failure to support seat section during service could result in death or severe injury.

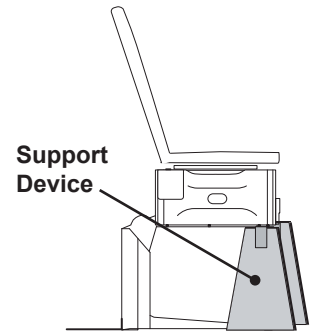

Figure 43.

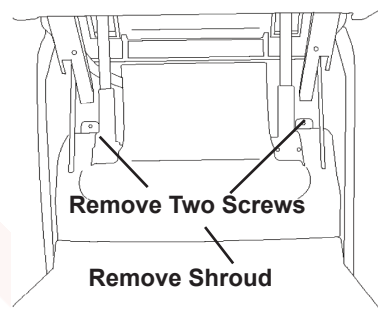

Figure 44.

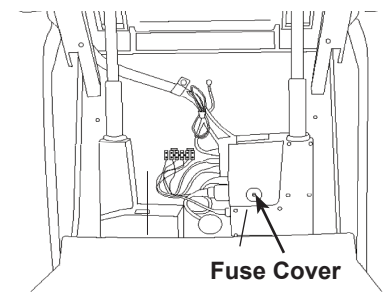



Figure 45.

NOTICE	
Prevent Fuse Cover Damage Pull fuse cover straight out. DO NOT TWIST.	

5. Replace fuses using spare fuses in fuse cover. Fuse type is 250V/2.5AT for 115 VAC.
6. Reassemble.

Control Box Fuse Replacement (for tables with the seat in the down position)

⚠ WARNING	
	Shock Hazard Disconnect power by removing plug from the power outlet before changing fuses.

1. Remove the (2) screws that secure the rear cover (Figure 46).
2. Remove the rear cover by tipping the top of the shroud away from the table and lifting up.
3. Swing the cover to the right using caution to not pull on the cabling.
4. Apply upward pressure on the control box while unscrewing the control box securing screw (Figure 47).
5. Push inner shroud forward (Figure 48) while sliding the control box off of the actuator (Figure 49).
6. See steps 3 & 4 of the above set of instructions for control box fuse replacement.
7. Replace fuses using spare fuses in fuse cover. Fuse type is 250V/2.5AT for 115 VAC.
8. Reassemble. *NOTE: The control box and actuator have mating slots. Be sure that the slots slide together to engage control box with actuator.*

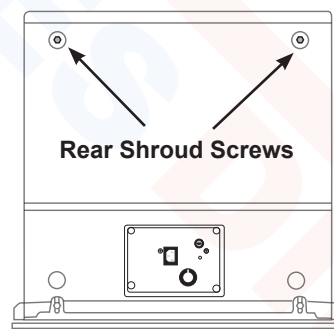

Figure 46.

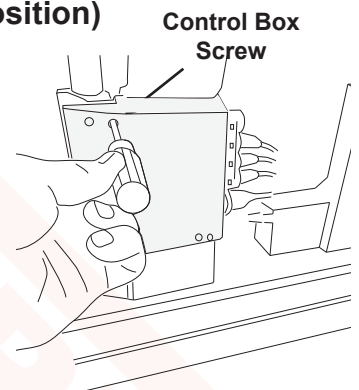

Figure 47.

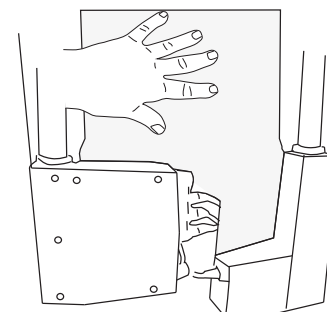

Figure 48.

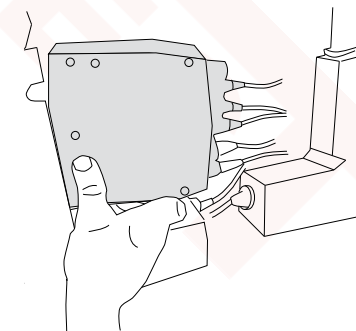

Figure 49.

OPTIONS AND ACCESSORIES

Listed below are the options and accessories which are authorized for use with this table.

Description	Order No.	Use/Restrictions
Armrest Hole Cap	101872	Covers hole created when user chooses to remove grab bars.
Debris Pan-Stainless Steel (Treatment Pan)	98464	Stainless steel pan for disposing of debris during procedures - located beneath leg support pad.
Drawer Organizer-Front	100407	Front drawer dividers for separation and organization.
*Grab Bar Kit (Field Installed)	2102895	Contains two grab bars, decorative side shrouds and sockets for tables not currently having grab bars. To replace existing grab bars see COMMON SERVICE PARTS.
<i>All three items below are required for knee crutch use. Purchase any item listed that is not currently on your table.</i>		
Knee Crutches-Deluxe Articulating	99504	Allows leg positioning for comfort and ease of examination.
*Knee Crutch Adapters (Field Installed)	100550	Provides attachment point for Knee Crutch Clamps.
Knee Crutch Clamp	99502	To hold deluxe articulating knee crutches - (1) clamp only.
*Pass Through Work Surface (Field Installed)	2102896	Contains Work Surface and hardware. Provides surface for laptop, paper work, blood draw items etc.
*Stirrup Kit no Outlet (Field Installed)	2102898	Contains two Stirrups and hardware for adding Stirrups to tables without outlets and not currently having stirrups.
*Stirrup Kit with Outlet (Field Installed)	2102897	Contains two Stirrups and hardware for adding Stirrups to tables with outlets and not currently having stirrups.
Urology Tray w/Hose & Bucket	100253	Conveniently and safely disposes of and captures fluids during urology procedures.
*Welch Allyn IV Light Bracket (Field Installed)	102032	For mounting of Welch Allyn IV light to side of table. <i>(Light not included)</i>
*Work Surface-Pass Through (Field Installed)	2102896	Work surface that stows beneath seat upholstery - passes to either side providing a surface for lab, paper work etc.

* "Field Installed" means that the table did not come from the factory with this feature built in. Order this option or accessory to add it to the table you currently have.

COMMON SERVICE PARTS

Listed below are the common service parts and kits which are authorized for use with this table.

Description	Order No.	Use/Restrictions
Armrest Hole Cap	101872	Covers hole created when user chooses to remove grab bars.
Debris Pan-Plastic (Treatment Pan)	2102836	Plastic pan for disposing of debris during procedures - located beneath leg support pad.
Debris Pan-Stainless Steel (Treatment Pan)	98464	Stainless steel pan for disposing of debris during procedures - located beneath leg support pad.
Foot Control (Single-pedal for manual back models 5700 and 5701)	2102848	Replacement for a single-pedal foot control.
Foot Control, (Two-pedal with Return-To-Chair feature 5800 & 5801)	2102858	Replacement for a 2-pedal foot control with return to chair feature only.
Fuse 3A	2102490	3A drawer warmer / outlet fuse (qty. 1)
Grab Bar Kit (Factory Installed)	2102891	Contains two Replacement Grab Bars. Used on tables currently having grab bars.
*Knee Crutch Adapters (Factory installed)	100540	Replacement Knee Crutch Adapters on tables currently having adapters installed.
Leg Support	2102774	Replacement pull-out metal support with slides and hardware.
Leg Support Hardware	2102775	Hardware kit for leg support. Contains screws, magnet, tension springs etcetera.
Leg Support Pad	2102776	Replacement upholstered leg support pad
*Pass Through Work Surface (Factory Installed)	2102892	Contains Work Surface and hardware. Provides surface for laptop, paper work, blood draw items etc.
Stirrup Indexer Kit	2102270	Contains the black components, screws and springs through which the stirrup beam passes.
*Stirrup Kit with Outlet (Factory Installed)	2102893	Contains two Stirrups and hardware for replacing Stirrups on tables with outlets not currently having stirrups.
*Stirrup Kit without Outlet (Factory Installed)	2102894	Contains two Stirrups and hardware for adding Stirrups to tables without outlets not currently having stirrups.
Upholstery, Replacement	5715-XX	Replacement top with hardware for the 5700, 5701,5800 and 5801 examination tables in 15 standard colors. Includes upholstered foot pad.
Urology Tray w/Hose & Bucket	100253	Conveniently and safely disposes of and captures fluids during urology procedures.
*Welch Allyn IV Light Bracket (Factory Installed)	102031	For mounting of Welch Allyn IV light. <i>(Light not included)</i>

* "Factory Installed" means that the table came from the factory with this option or accessory already built in. Order this service part or kit to replace this component or hardware.